



SAN ANTONIO  
**ALAMODOME**

---

# EVENT PLANNING GUIDE



**100 MONTANA ST. SAN ANTONIO, TEXAS 78203**



## Table of Contents

<b>Facility Overview</b> .....	03
<b>Staff Directory</b> .....	04
<b>About San Antonio</b> .....	06
<b>Building</b> .....	08
Configurations .....	09
Locker Rooms, Backstage Rooms, Meeting Rooms.....	19
Press Box & Coaches/Broadcast Booths.....	21
Suites .....	22
Hospitality Spaces .....	23
Parking .....	24
Load In/Out .....	22
<b>Planning &amp; Services</b> .....	24
Booking & Event Services.....	28
Box Office & Ticketing.....	30
Building Policies .....	31
Public Safety Policies .....	33
Open & Concealed Carry .....	36
Guest Services .....	37
Advertising & Promotion.....	39
<b>Production</b> .....	43
A/V Specs .....	44
A/V Equipment & Personnel.....	47
Power Map.....	49
Rigging and Load Capacities .....	50
Roof Grid & Catwalk .....	51
Fire Safety Requirements .....	52
Permitting.....	53
Current Equipment & Labor Rates .....	54

# FACILITY OVERVIEW



## The Alamodome

Opened in 1993, the Alamodome has consistently cast its spotlights on an incredible range of entertainment and sporting events. The Alamodome is a versatile facility with over 160,000 square feet of flexible space, hosting an average of 150 events per year. The Alamodome is a city-owned and operated multipurpose facility located in the heart of downtown San Antonio.

### Architect:

Populous  
Marmon Mok  
W.E. Simpson Company

### General Contractor:

Huber, Hunt & Nichols

### Owner & Operator:

City Of San Antonio

### Tenants:

San Antonio Sports  
UTSA Roadrunners Football  
Valero Alamo Bowl



# STAFF DIRECTORY

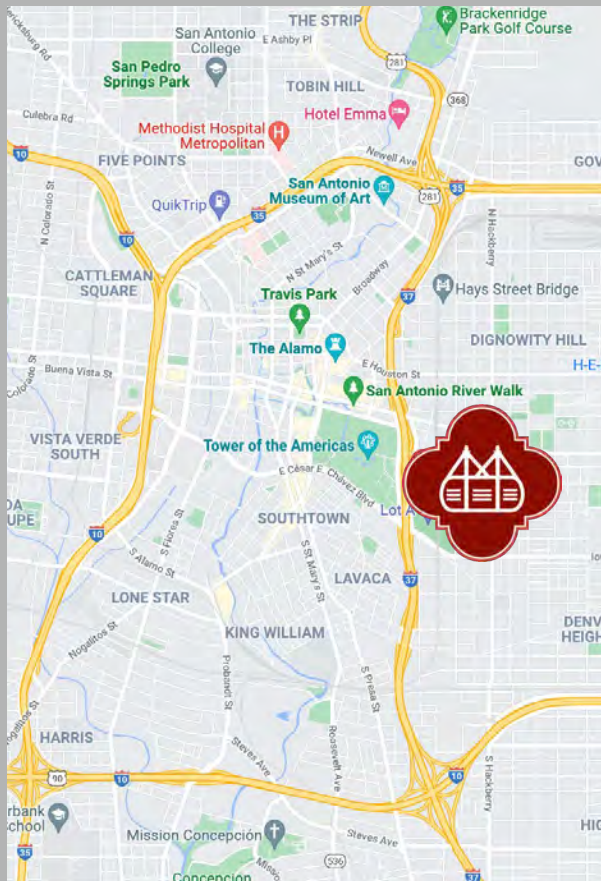

## Address

**100 Montana Street  
San Antonio, TX 78203**

**Main Switchboard: 210.207.3663**

**Main Fax Number: 210.207.3646 (DOME)**

**Alamodome Public Safety (24/7):  
210.207.3680**

## Website

**alamodome.com**

## Social Media

**Facebook.com/Alamodome**

**X: @Alamodome**

**Instagram: @alamodomesa**

## Administration

Stephen Zito, Assistant Director, CSEF/Alamodome  
Stephen.Zito@sanantonio.gov | 210.207.3605

## Business and Finance

Michael Flores, General Manager  
Michael.Flores@sanantonio.gov | 210.207.3620

Javier Tamez, Business Manager  
Javier.Tamez2@sanantonio.gov | 210.207.3650

Denise Reyes, Administrative Assistant II  
Denise.Reyes@sanantonio.gov | 210.704.6330

## Box Office

Roger Morse, Box Office Administrator  
Roger.Morse@sanantonio.gov | 210.207.3609

Rozanna Santos, Box Office Manager  
Rozanna.Santos@sanantonio.gov | 210.207.3635

## Event Services

Paula Hobbie, Event Services Manager  
Paula.Hobbie@sanantonio.gov | 210.207.3671

Edward Miranda, Senior Events Coordinator  
Edward.Miranda@sanantonio.gov | 210.207.3636

Andrea Austin-Thomas, Senior Event Coordinator  
Andrea.Austin-Thomas@sanantonio.gov |  
210.207.3602

Alex Legg, Event Coordinator  
Alex.Legg@sanantonio.gov | 210.207.3642

## Food & Beverage Services

### *Legends Global*

Beatriz Valenzuela,  
General Manager of Food and Beverage  
bvalenzuela@savorbt.com | 210.906.1495

Matt Evans, Director of Hospitality & Strategy  
Strategy.maevans@savorbt.com | 386.837.4541

## **Guest Services**

Tiffany Vidales, Customer Service Specialist  
Tiffany.Vidales@sanantonio.gov | 210.207.3607

## **Maintenance and Engineering**

Eric Duncan, Building Maintenance Manager  
Eric.Duncan@sanantonio.gov | 210.207.3608

Vincent Medina, HVAC Supervisor  
Venancio.Medina@sanantonio.gov | 210.207.3668

## **Operations**

Tom McAfee, Building Operations Manager  
Thomas.McAfee@sanantonio.gov | 210.207.3754

## **Parking Services**

Frank Anaya, Parking Manager  
Frank.Anaya@sanantonio.gov | 210.207.3753

## **Public Safety Services**

Public Safety Manager  
Dome\_Security@alamodome.com | 210.207.3685

## **Event Guest & Security Services**

Richard Campbell, Branch Manager  
richard.a.campbell@aus.com | 210.704.6752

## **Fire Prevention Services**

SAFD Special Events Office | 210.207.3695

## **Law Enforcement Services**

SAPD Off-Duty Office | 210.207.7020

## **Sales and Marketing**

Toryn Jones, Sales and Marketing Administrator  
Toryn.Jones@sanantonio.gov | 210.207.3752

Victor Cabarello, Marketing Manager  
Victor.Cabarello@sanantonio.gov | 210.207.3691

Rick Garcia, Design Communications Coordinator  
Rick.Garcia@sanantonio.gov | 210.207.3626

Henry Jaime, Audio/Visual Production Coordinator  
Henry.Jaime@sanantonio.gov |

Lenzy Mora, Graphic Designer  
Lenzy.Mora@sanantonio.gov | 210.207.3682

## **Technical Services**

Jason Bippert, Telecommunications Manager  
Jason.Bippert@sanantonio.gov | 210.207.3629

Manuel Corales, Audio/Visual Production Supervisor  
Manuel.Corales@sanantonio.gov | 210.207.3640

# About San Antonio...

## Airport

Located in north central San Antonio, the San Antonio International Airport (SAT) is only 8.5 miles from the downtown business district - about a 15-minute drive - which is unusual for major metropolitan areas.

## Public Transportation

Getting around San Antonio and downtown is a breeze with our wide selection of transportation options, including the VIVA by VIA service, River Taxi, Cabs, Uber, and Lyft.

## Driving

### FROM IH-35 SOUTH

Take US-90 East to New Braunfels Street exit, north on New Braunfels to Commerce Street, west on Commerce Street to Cherry Street, south on Cherry Street and into lots.

### COMING FROM IH-10 EAST

Use Hackberry Street exit, north on Hackberry to Cesar Chavez Blvd., west on Cesar Chavez Blvd. to Cherry Street, North on Cherry Street and into lots.

### COMING FROM IH-10 WEST

Use IH-35 north to New Braunfels Street exit, south on New Braunfels to Commerce Street, West on Commerce Street to Cherry Street, south on Cherry Street and into lots.

### COMING FROM IH-37 SOUTH

Use Cesar Chavez Blvd. exit, east on Cesar Chavez Blvd. to Cherry Street, north on Cherry Street and into lots.

### COMING FROM US 281 NORTH

Use Cesar Chavez Blvd. exit, east on Cesar Chavez Blvd. to Cherry Street, north on Cherry Street and into lots.

## Hotels

With over 14,000 hotel rooms in downtown San Antonio there are endless lodging options within walking distance of the Alamodome. A Visit San Antonio representative can assist with all travel needs. See VisitSanAntonio.com for more information.

## Recreation/Attractions

Home to the legendary Alamo and world-famous River Walk, San Antonio offers a wide range of exciting and unique activities. San Antonio has five theme parks, working ranches, rivers to float, and 300 days of sunshine perfect for golfing one of our 50 courses. In San Antonio there is something for everyone.

## Dining

While San Antonio is famous for Tex-Mex, you'll also find traditional Mexican cuisine along with German, French, English and Italian eateries. The venues are just as varied as the types of cuisine they serve. From white tablecloth to savory food trucks to genuine steakhouses and BBQ joints, there's always something new and different to try.

## Shopping

According to Forbes.com, San Antonio is one of America's top ten best cities to shop. With several malls and local shops displaying handmade items, you can take home both the culture of San Antonio and the latest fashion trends.

## Hospitals

Multiple medical facilities are available within two miles of the Alamodome (Baptist Medical Center, The Children's Hospital of San Antonio), as well as a short six mile drive to a major medical complex of several hospitals with nationally recognized physicians and research facilities.

# SAN ANTONIO DOWNTOWN AREA



For more information on hotels, restaurants, events and sightseeing tours, come by the Official Visitor Information Center at 317 Alamo Plaza or call toll free 800-447-3372. Located directly across from the Alamo. OPEN SEVEN DAYS A WEEK (CLOSED: New Year's Day, April 24th – Battle of Flowers Parade, September 30th, Thanksgiving Day and Christmas Day).





# BUILDING

The Alamodome is a unique facility with the flexibility to host a wide variety of events. The following are examples of the more common configurations, however any plan can be adjusted to meet specific event needs.

## Capacities Per Configuration

**Full Stadium- Football & Soccer: 62,834**

**Full Stadium - South Stage: 56,016**

**Full Stadium - In The Round: 71,296**

**Full Stadium - Boxing In The Round: 68,830**

**Modified Arena Boxing: 29,264**

**Arena Boxing: 35,562**

**Arena Graduations: 29,476**

**Modified Arena South Stage: 30,648**

**Arena East Stage: 25,507**



# Full Stadium - South End Stage

\*The estimated capacity includes the typical number of floor seats (11,064) for this configuration. Capacities based on your needs may vary.

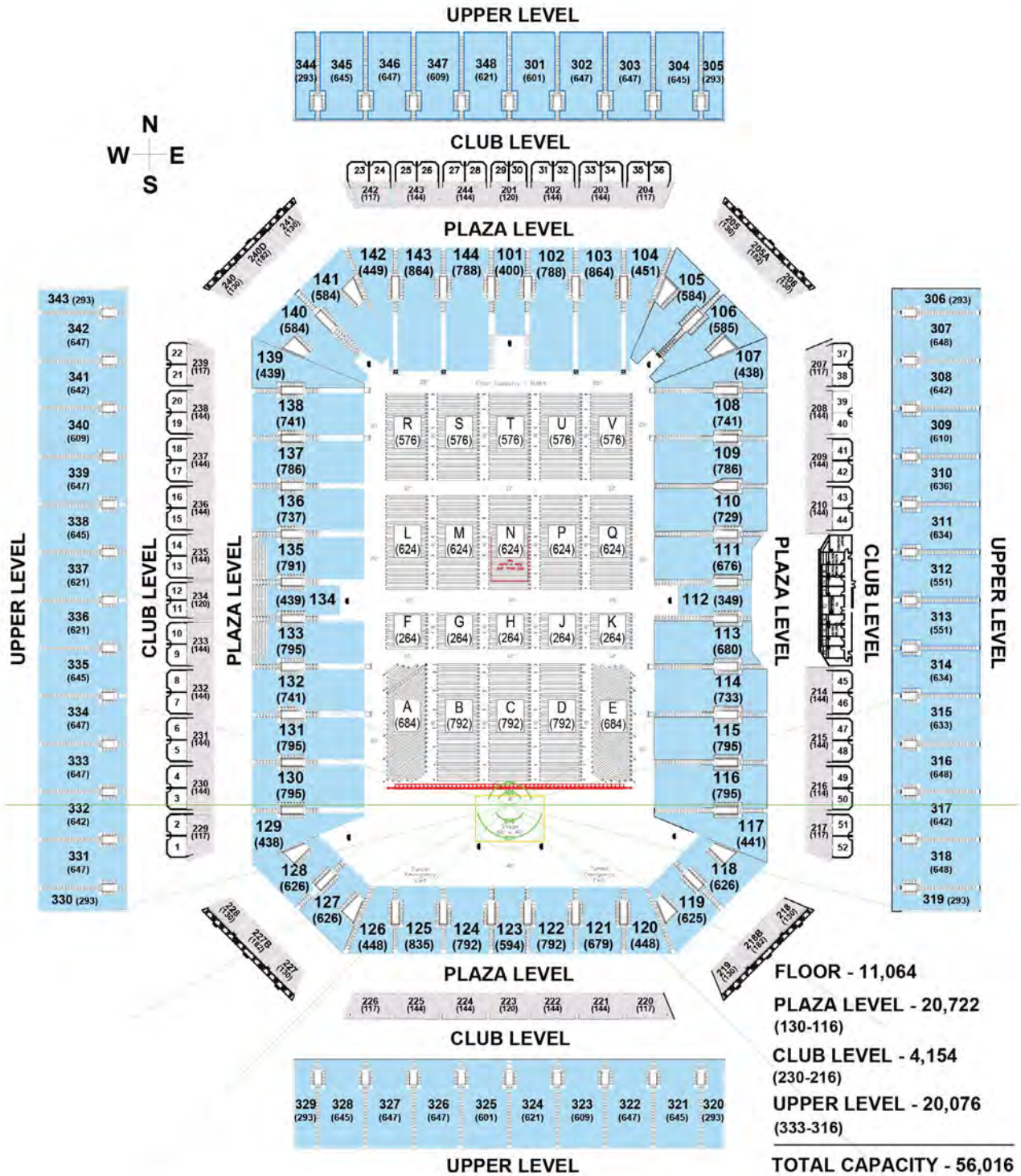

laskercadservices.com

Stadium  
South End Stage  
(56,016)



04/28/22

# Full Stadium - In The Round

\*The estimated capacity includes the typical number of floor seats (9,252) for this configuration. Capacities based on your needs may vary.

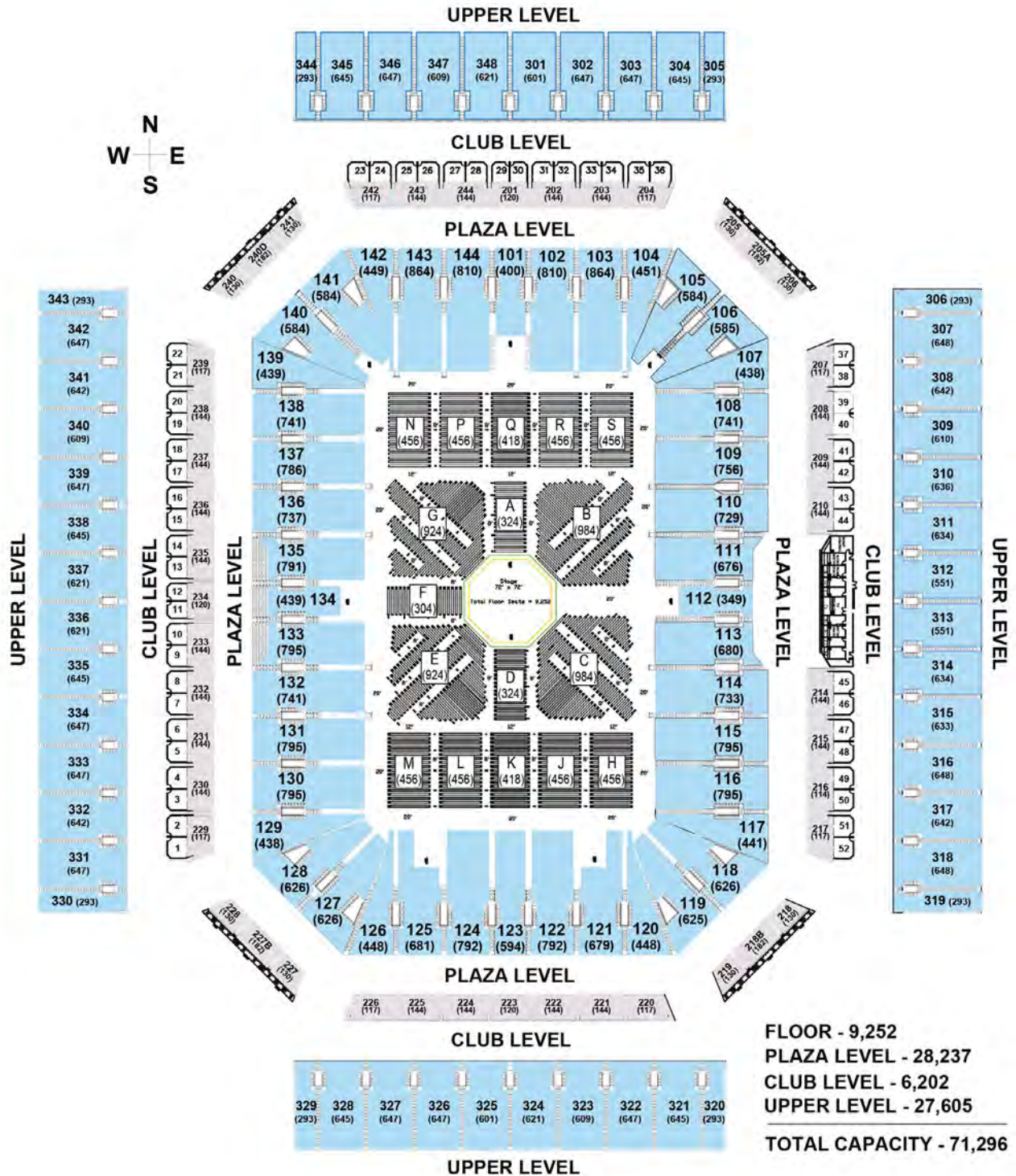

# Full Stadium - Boxing In The Round

\*The estimated capacity includes the typical number of floor seats (5,996) for this configuration. Capacities based on your needs may vary.

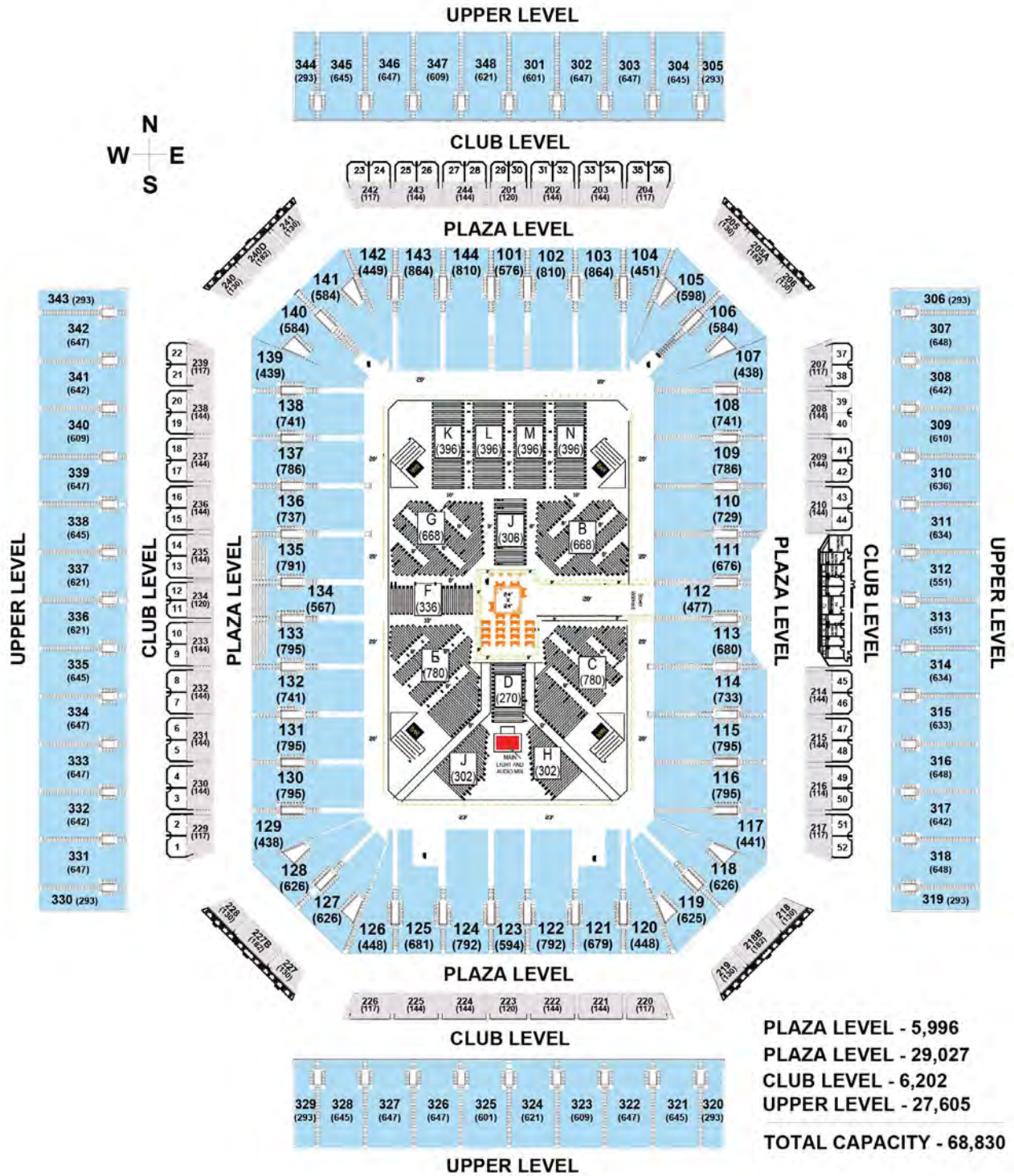

laskercadservices.com

Stadium  
Boxing In The Round  
(68,830)



02/23/22

# Modified Arena - Boxing

\*The estimated capacity includes the typical number of floor seats (2,150) for this configuration. Capacities based on your needs may vary.

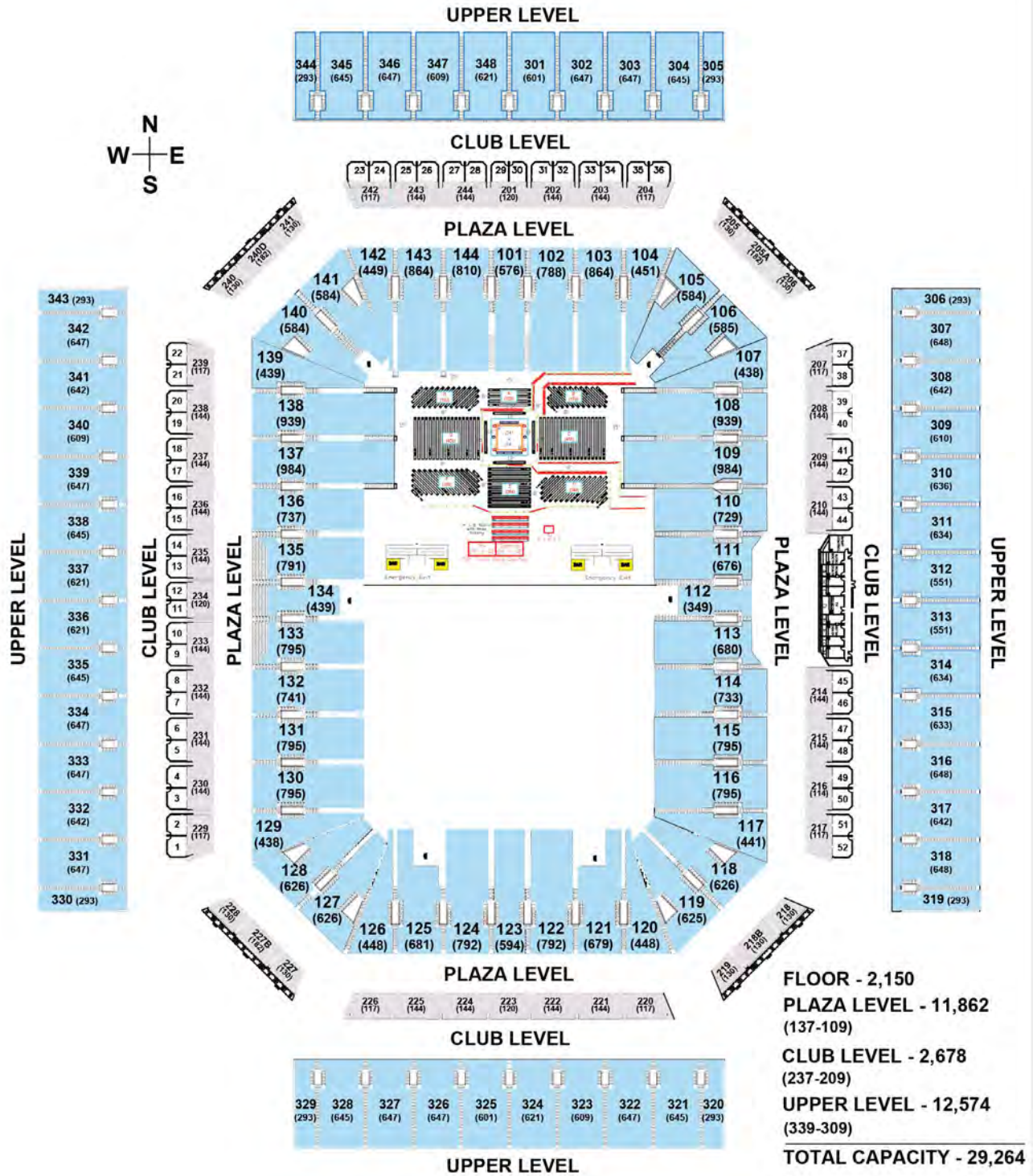

laskercadservices.com

Modified Arena  
Boxing  
(29,264)



02/22/22

# Arena - Boxing

\*The estimated capacity includes the typical number of floor seats (2,004) for this configuration. Capacities based on your needs may vary.

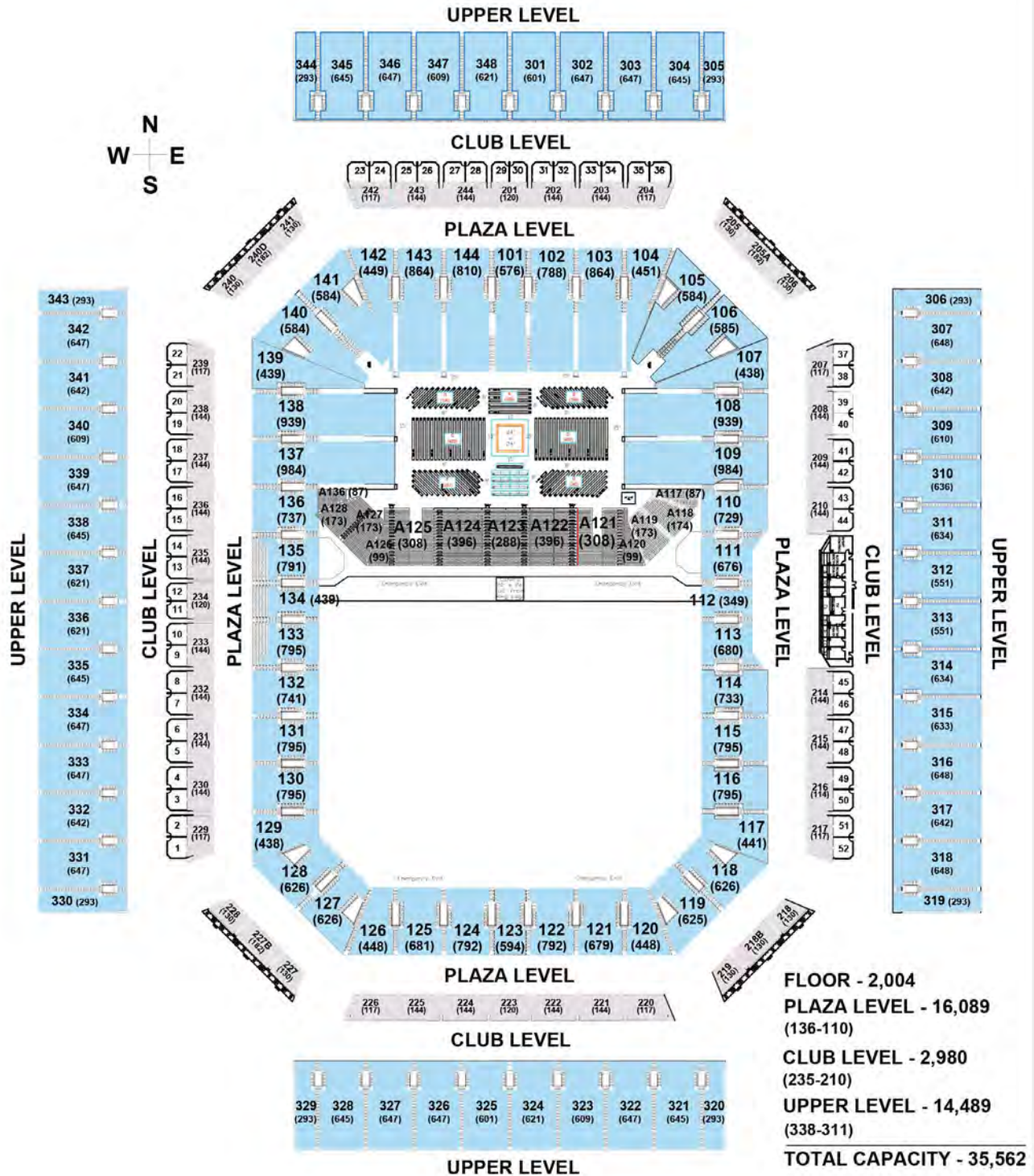

laskercadservices.com

Arena  
Boxing  
(35,562)



02/23/22

# Arena - Graduation

\*The estimated capacity includes the typical number of floor seats (1,440) for this configuration. Capacities based on your needs may vary.

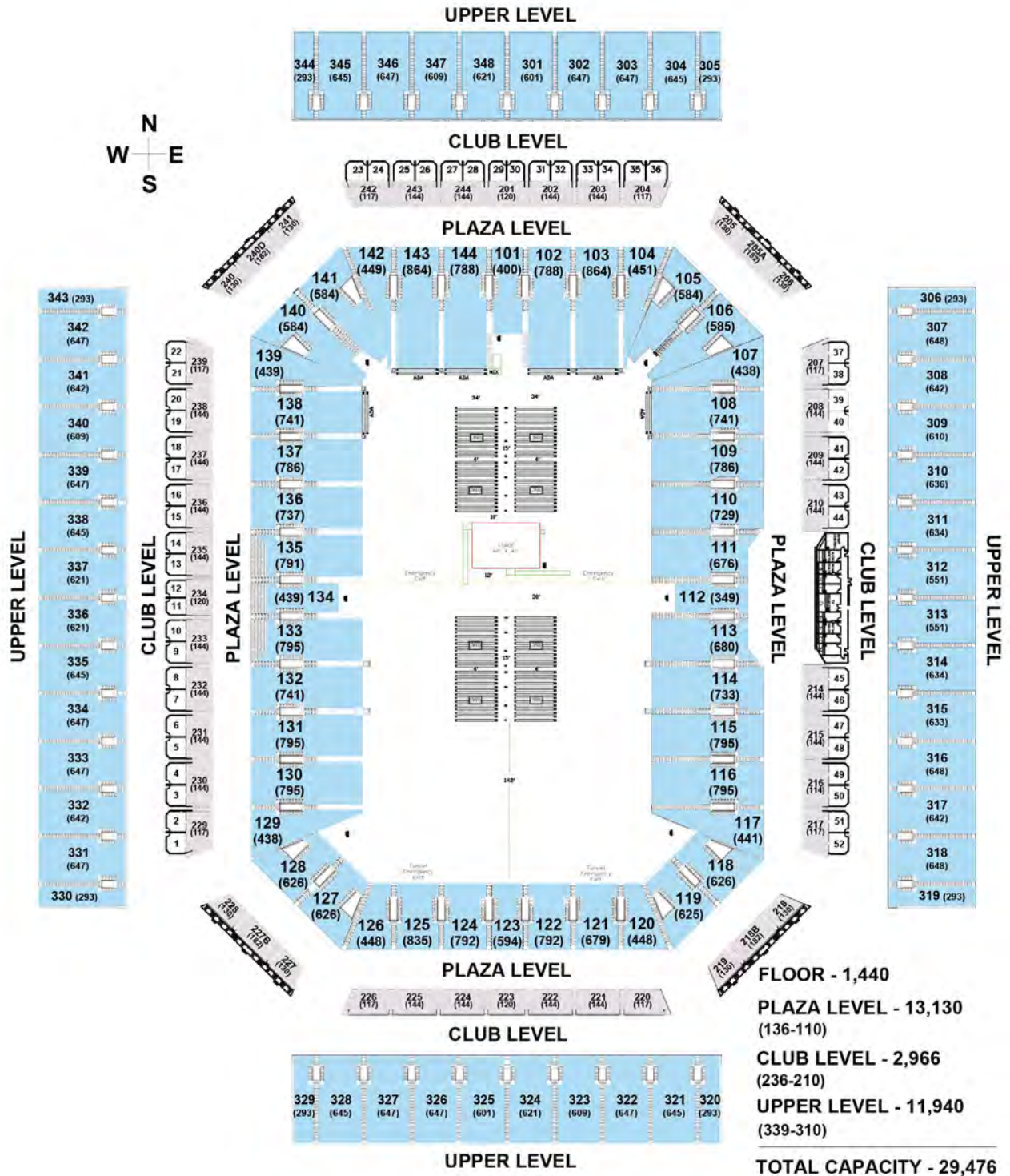

laskercadservices.com

Arena  
Graduation  
(29,476)



04/28/22

# Modified Arena - South Stage

\*The estimated capacity includes the typical number of floor seats (2,612) for this configuration. Capacities based on your needs may vary.

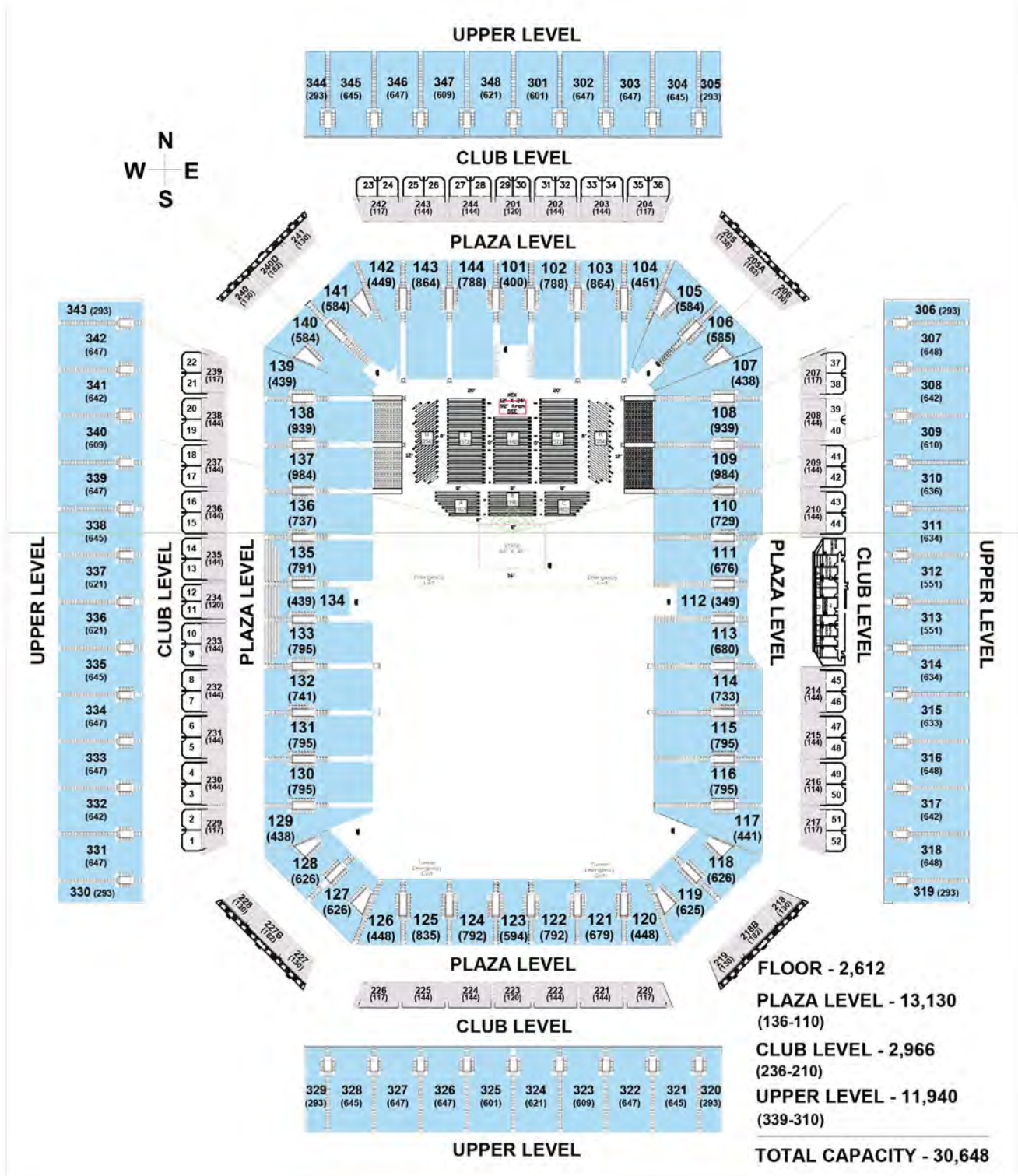

laskercadservices.com

Modified Arena  
South Stage  
(30,648)



03/09/22

# Arena - East Stage

\*The estimated capacity includes the typical number of floor seats (2,574) for this configuration. Capacities based on your needs may vary.

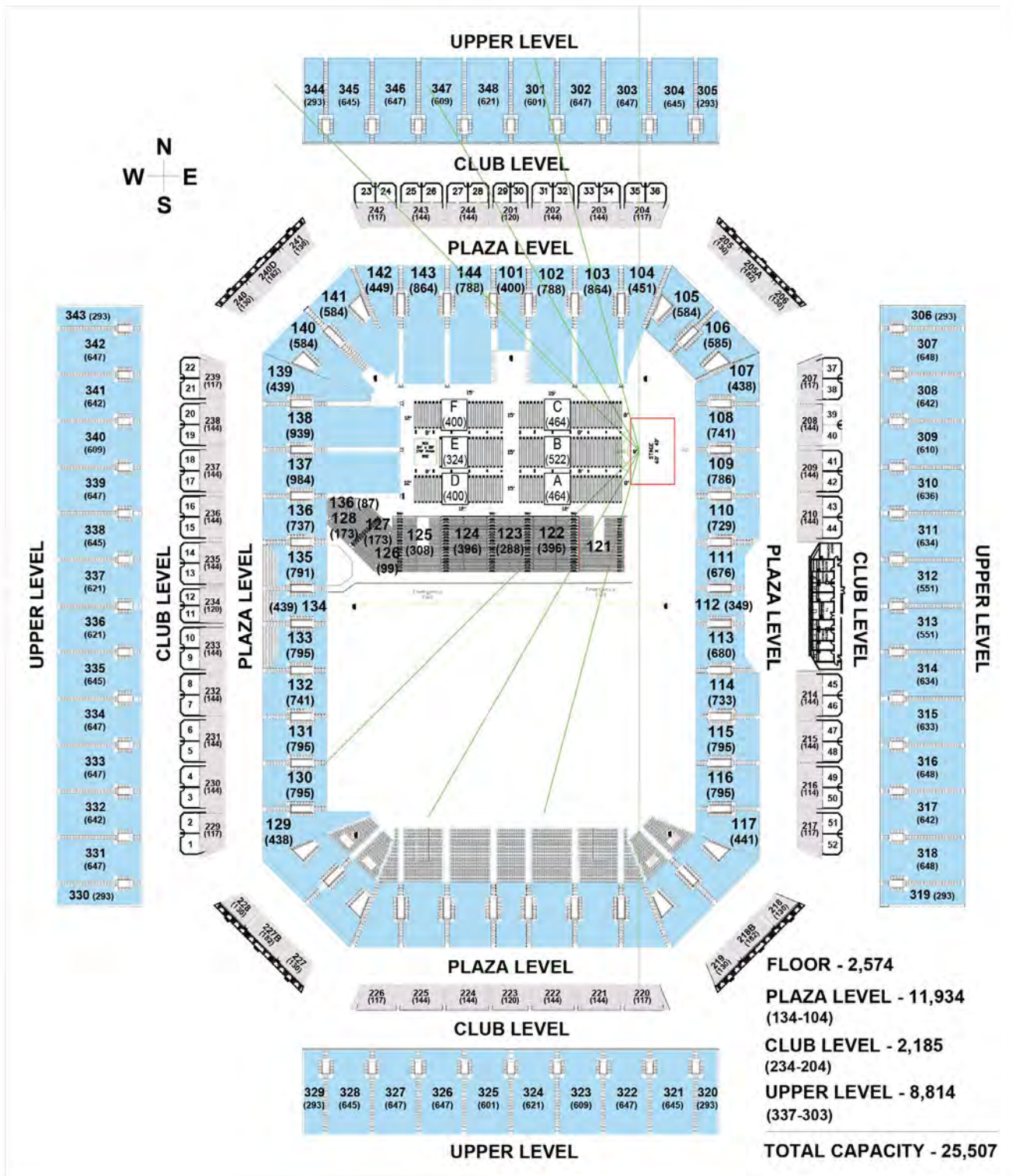

laskercadservices.com

Arena  
East Stage  
(25,507)



04/28/22

# Tradeshow

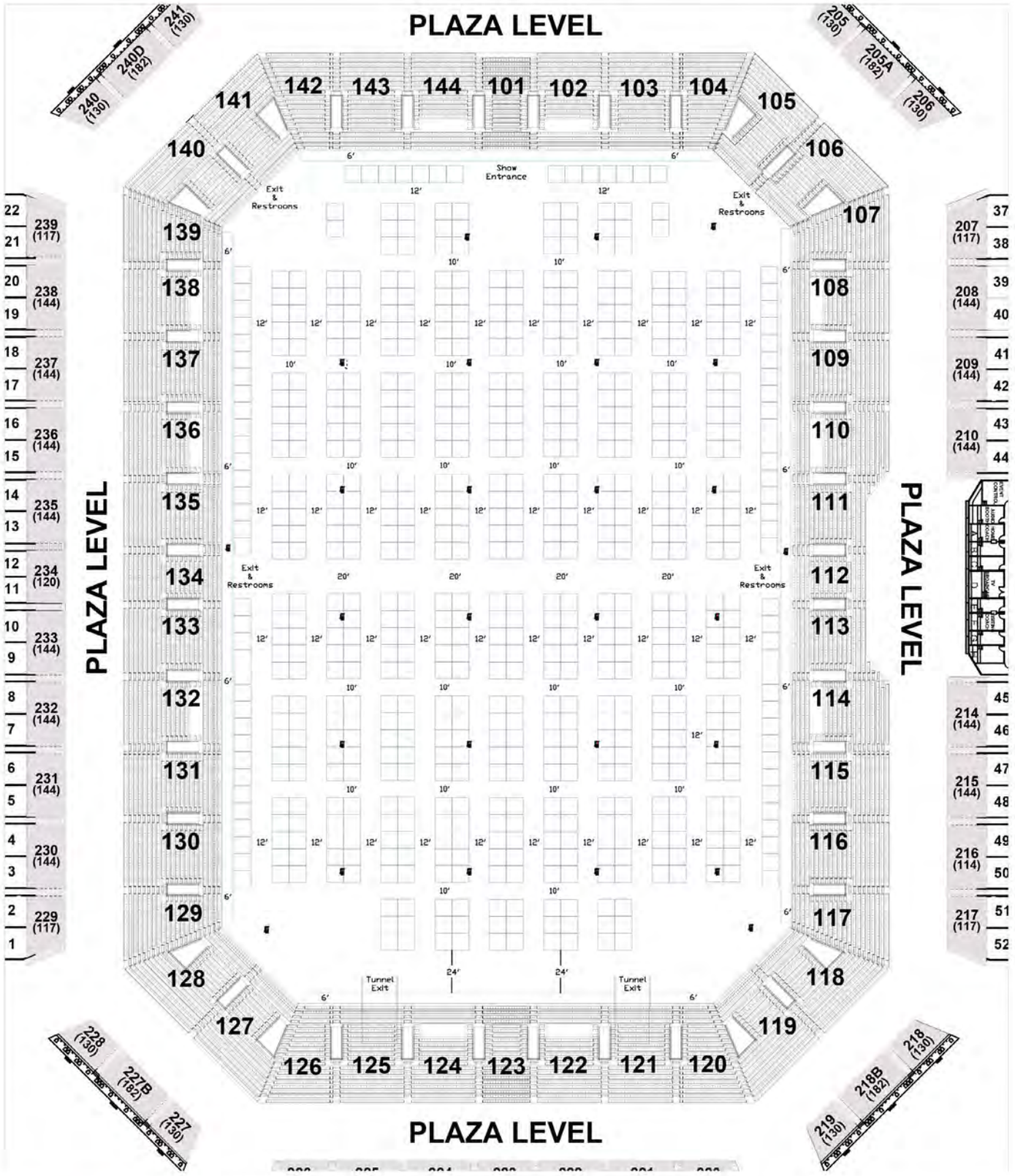

**LASKER**  
 CAD SERVICES  
[laskercadservices.com](http://laskercadservices.com)

Stadium  
 Trade Show  
 (680 10' x 10' Booths)

03/03/22

# Room Configurations

## Locker Rooms - Backstage Rooms

Room Name*	Square Feet	Restrooms	Showers	Lockers	Additional Features
Locker Room A	1,071	X	X	32	Head Coach Locker Room w/shower
Locker Room B	897	X	X	39	Head Coach Locker Room w/shower
Locker Room C	897	X	X	40	Head Coach Locker Room w/shower
Locker Room D	1,174	X	X	33	Head Coach Locker Room w/shower
NE Locker Room	5,300	X	X		Head Coach Locker Room w/shower
Home Team Locker Room	7,500	X	X	132	Equipment Room, Training Room, Coaches Lounge,
W. Officials Locker Room	500	X	X	13	
E. Officials Locker Room	500	X	X	13	
X-Ray Room	391				
Visitors Interview Booth	180				Broadcast Connections
Home Interview Booth	180				
Production Office	1,700				Air wall divider equipped
North Dressing Room	166	X	X		Part of Production Office Compound
South Dressing Room	166	X	X		Part of Production Office Compound
Green Room	977	X			

\* Please note that Locker Rooms A/B and C/D are air wall equipped and may be combined.  
Production Office and NE Locker Room are wall equipped and may be split in half.

# Room Configurations

## Meeting Rooms

Meeting Rooms	Gross Sq. Ft.	Approx Room Size	Theater	Classroom	Banquet	Ceiling Height
A	1,506	37'x42'	104	52	63	12' 6"
B	2,338	37'x63'	156	78	94	12' 6"
A&B	3,844	37'x105'	260	130	157	12' 6"
C	1,830	41'x45'	123	62	74	12' 6"
D	1,830	41'x45'	123	62	74	12' 6"
C&D	3,660	41'x90'	246	124	148	12' 6"
F	2,338	37'x63'	156	78	94	12' 6"
G	1,506	37'x42'	104	52	63	12' 6"
F&G	3,844	37'x105'	260	130	157	12' 6"
I	1,830	41'x45'	123	62	74	12' 6"
J	1,830	41'x45'	123	62	74	12' 6"
I&J	3,660	41'x90'	246	124	148	12' 6"
K	3,059	37'x83'	205	103	123	12' 6"
L	3,059	37'x83'	205	103	123	12' 6"
K&L	6,118	37'x166'	410	206	246	12' 6"
M	1,149	37'x32'	79	40	48	12' 6"
N	2,159	41'x54'	148	74	89	12' 6"
O	1,826	41'x54'	123	62	74	12' 6"
P	1,826	41'x54'	123	62	74	12' 6"
N/O/P	5,811	41'x144'	394	198	237	12' 6"

## Press Box

### Details

- Seating for 150 persons
- Located on the East 50-yard line Mezzanine level
- An additional room measuring 16'x41' is also available
- Four (4) Auxiliary Press areas can be created throughout the Mezzanine level, each seating approximately 30 persons.

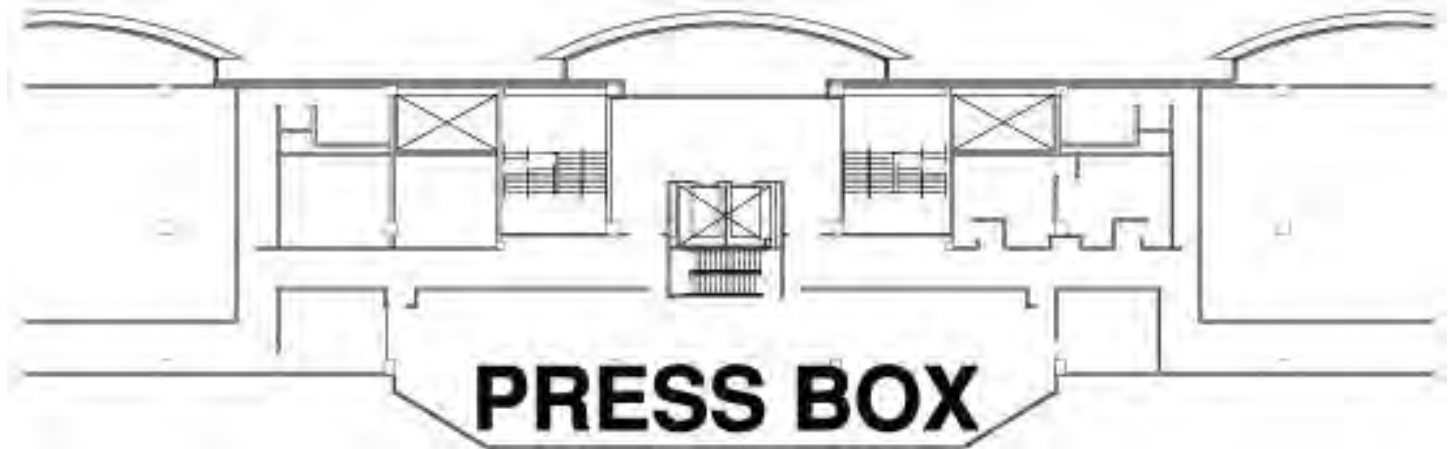

## Coaches/Broadcast Booths

### Details

- 9 total booths available (A-I)
- Located directly above the Press Box on the East 50-yard line Club level
- Inner stairwell to Press Box for easy access

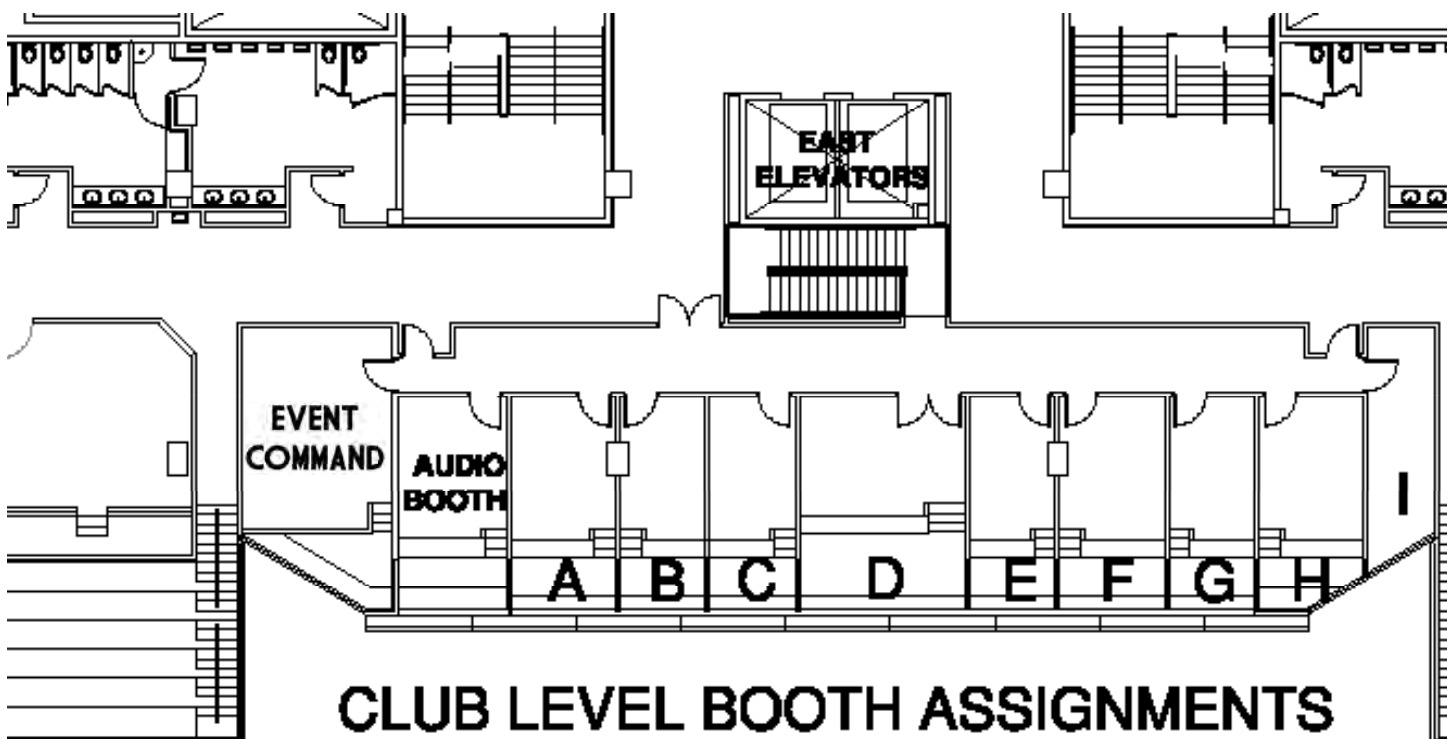



# Hospitality Spaces

## Hall of Fame Club

Located on the North end of the Club Level, the Hall of Fame Club offers over 4,000 square feet with spectacular views of the HEB Plaza and downtown San Antonio, two built in bars, and large flat screen TV's to enjoy the event from a private location.

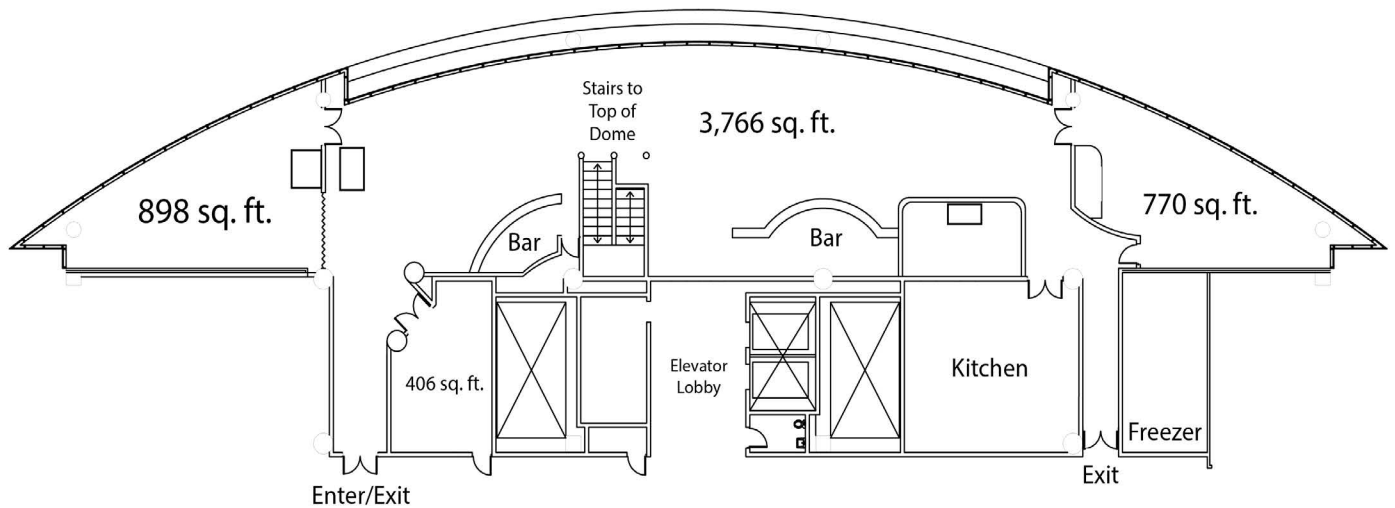

## Top of the Dome Club

Located on the North end of the Upper Level, the Top of the Dome Club can function as its own private 3,500+ square foot space, or use the connecting staircase to the Hall of Fame Club to double the size of your party.

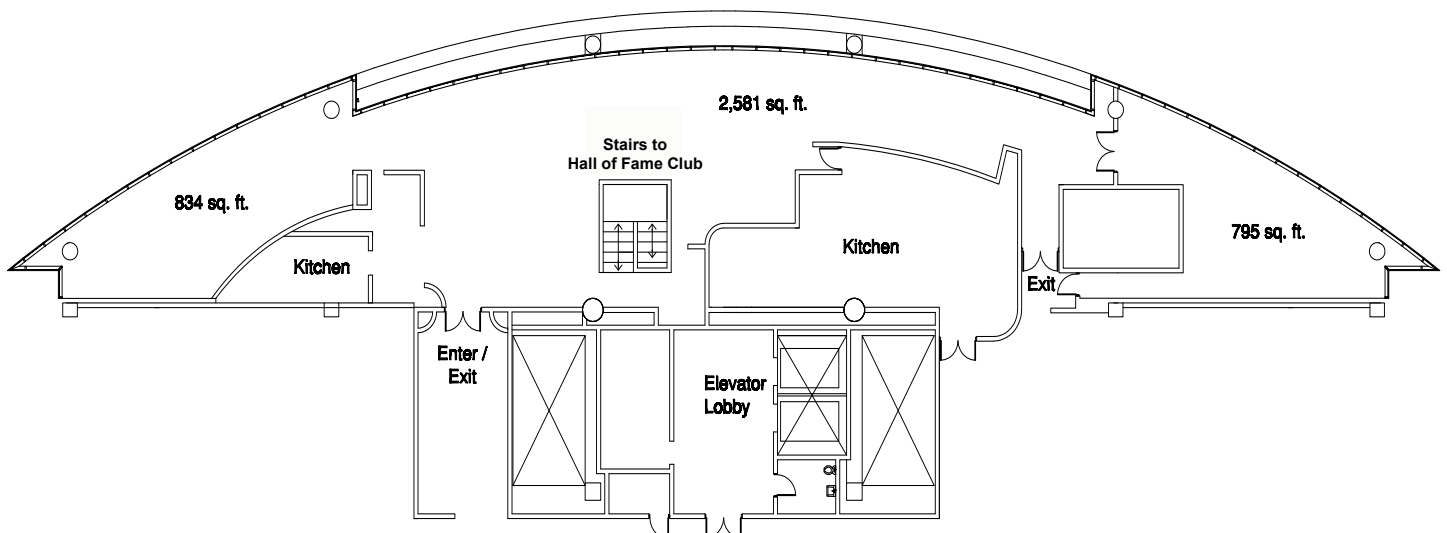

## South Club Eyebrow

Located on the South end of the Club Level, over 6,000 square feet of flexible and completely customizable space without any built in fixtures is the perfect place to make the Alamodome your own.

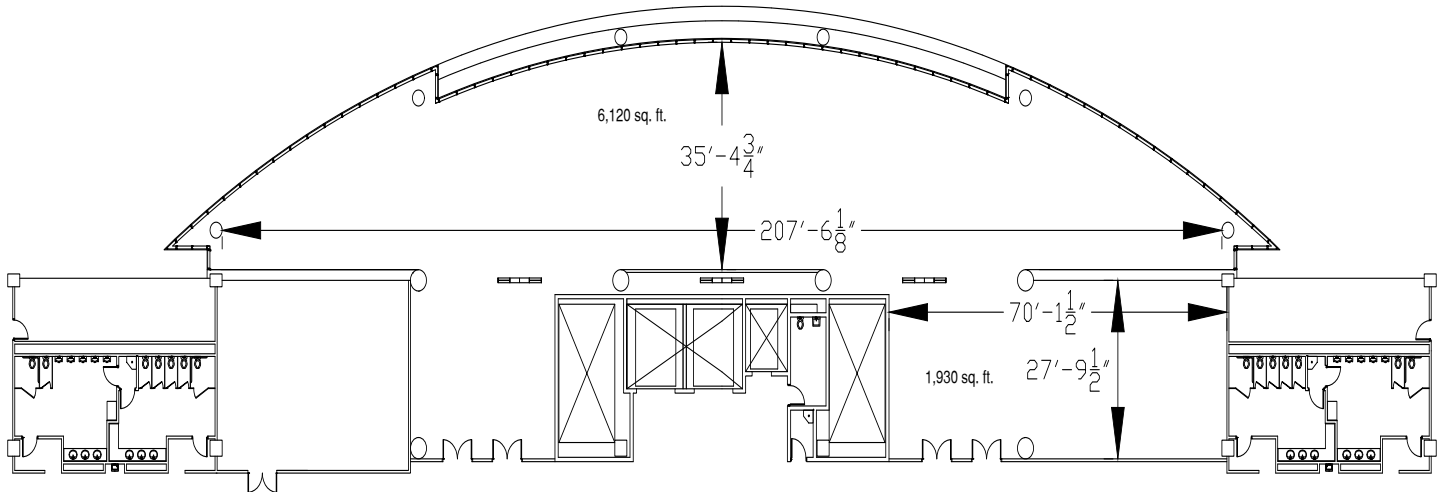

## Multi-purpose Room

This 23,000 square foot multi-purpose space is located on the North end of the field level. This brand new area features a separate loading dock, offering convenient access to Montana St.

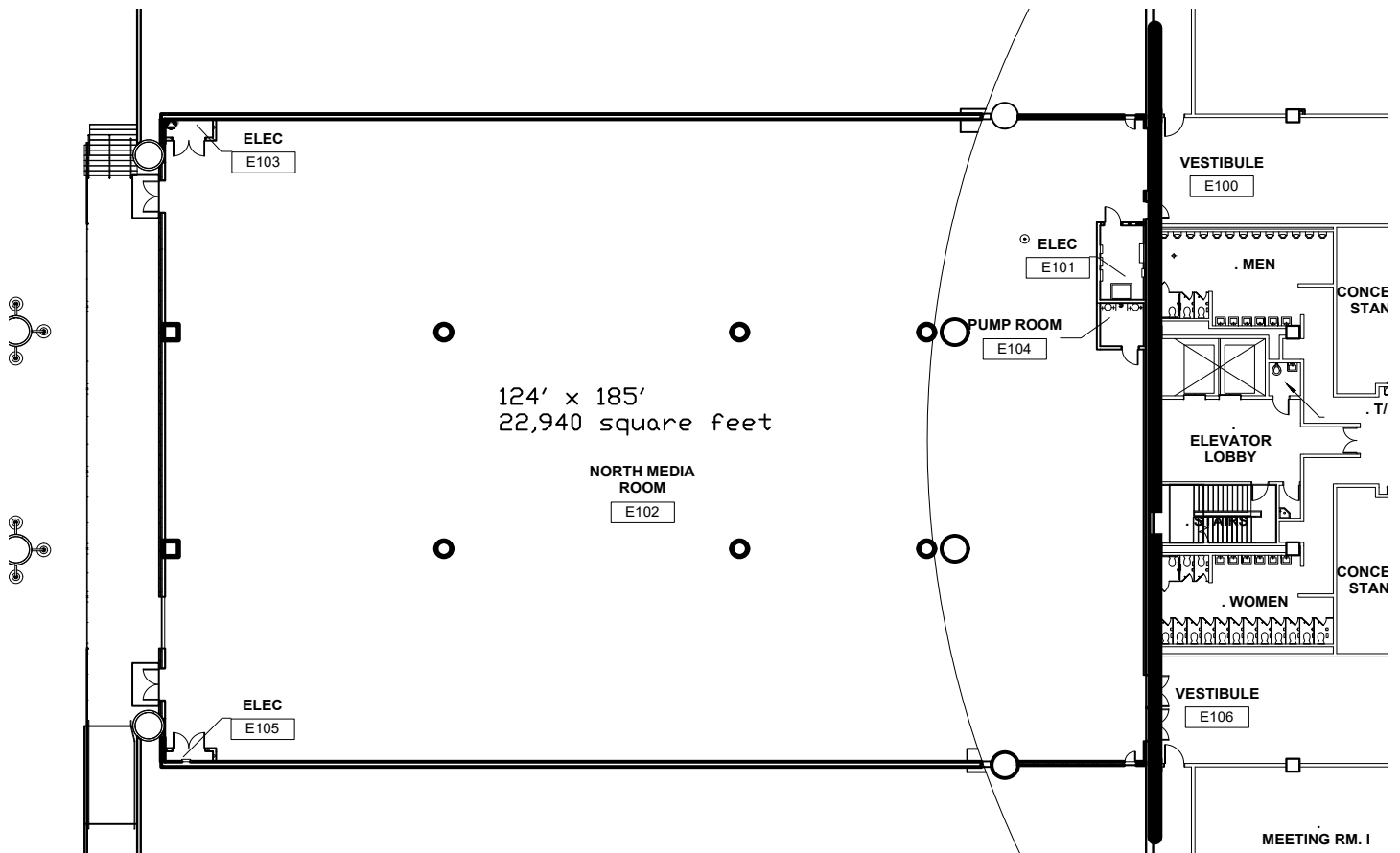

# Parking

At the Alamodome we understand that parking is an important concern for our event organizers and attendees, especially in a downtown setting. Our dedicated parking team has developed guidelines and procedures and will work with your Event Coordinator to plan and meet your transportation needs.



LOT	TOTAL SPACES	LOT SIZE SQ. FT.	ADA	BUS	LOCATION	RELATION TO BUILDING
A	482	334,683	127	12	Corner of East Cesar E. Chavez Blvd. and I-37 (U.S. Hwy. 281) Frontage Road	South
B	968	343,976	0	15	South Cherry Street	East
C	1,142	360,552	0	0	South Cherry Street	East
TOTAL	2,592					

## **Accessible Parking and Drop-Off**

Accessible parking is located in Lot A, off of the Northbound IH-37 access road, between César E. Chávez Blvd. and Montana St. The Alamodome provides 127 accessible spaces that are available on a first come, first served basis for vehicles with a valid State issued placard (blue or red) or license plate. Accessible parking is subject to the event parking rates. Complimentary drop-off and pick-up for patrons with disabilities is available in Lot A, as well as an accessible ramp leading to the Plaza level.

## **Patron and Ride Share Drop-Off/Pick-Up Area**

The drop-off and pick-up zone is available for quick access in Lot D located at Tower of the Americas Way (southbound I-37 access road) between Montana and César E. Chávez Blvd. Drop-off and pick-up at this location is the safest and quickest area for ride share, taxis, and limo access. There is a pedestrian walkway that leads directly from this location to the security checkpoint on the North Plaza of the Alamodome, Access Control Point (ACP A).

**Ride Share Zone Address:**

**500 Tower of Americas Way**

**San Antonio, TX 78205**

## **Bus Parking**

Bus entry and parking is available in the North section of Lot B, on Cherry Street, and is most easily accessed by entering the parking lot from the North.

## **Overnight Parking**

Overnight guest parking is not permitted in any of the Alamodome parking lots. Arrangements for production vehicles to stay overnight can be made through your Event Coordinator.

## **Traffic**

The San Antonio Police Department's Traffic Division assists the Alamodome with traffic direction during many events. The amount of police coverage depends on the Alamodome event size and scope.

## **Loading Dock**

### **Loading Dock Specifications**

- The loading dock is located at the south end of the Alamodome, in Parking Lot A, and is accessible via the Northbound I-37/U.S. Route 281 Frontage Road.

- The loading dock features 4,200 square feet of space including eight truck bays with two direct access tunnels to the stadium.
- Loading Dock bays measure 17' 9" wide and 10' high. Bays are 82' deep. Loading Dock Tunnel height is 13' 6".

## **Loading Dock Access**

- Loading Dock access is restricted to Loading Dock permit holders. Loading Dock parking permits may be obtained through your Event Coordinator.
- Persons requesting Loading Dock access to load and/or drop off equipment must be approved by the client and communicated to the Event Coordinator. Approved guests will be permitted to park in the designated 15-Minute Loading Zone parking spaces or in loading dock bays, as applicable, based on availability.
- Alamodome tenants may park in the 15-Minute Loading Zone parking spaces at any time, provided space is available and timing does not impact event operations.
- Commercial carriers will also be granted access to the appropriate loading dock bays, as designated by Security, upon availability.

## **Event Day Load In/Load Out**

- Licensee staff needing to load and/or unload in the Loading Dock area before the event is permitted to do so up to 2 hours prior to the start of the event. Licensee staff needing to load and/or unload after the end of the event may begin to do so 1 hour after the end of the event. There is no parking permitted in the loading dock area for these vehicles.

## **HEB North Plaza Vehicle Access**

- Vehicle access to the HEB Plaza on the North side of the Alamodome can be obtained with prior approval from your Event Coordinator. Access to the HEB Plaza will be limited to vehicles being used in the setup, display, or break down of events taking place on the Plaza. All vehicles entering through the North Plaza must maintain a maximum weight of 250 lbs. per sq. ft. or less.
- Access to the HEB Plaza via Sunset Station is blocked by bollards owned by VIA Metropolitan Transit. Clients must obtain approval from VIA Metropolitan Transit for the entry of vehicles with a gross weight of 40k lbs. or more.
- If you must enter through Sunset Station, please provide your Event Coordinator with a schedule of the times you will require the bollards to be staffed, at least a week in advance of your event.



# PLANNING & SERVICES

**In this section, you will find information regarding Booking, Event Services, Box Office and Ticketing, Building Policies, Gate Maps, Guest and ADA Services, Marketing and Advertising Services, Food and Beverage services.**

# Booking Services Division

## Event Booking

Questions regarding the availability of dates and booking procedures should be directed to the Booking Coordinator.

## Follow-Up Evaluation

Following your event, the Booking Services division will forward an evaluation of our facility and our staff. Your success and satisfaction is our top priority, and we welcome the opportunity to meet and exceed your expectations.

# Event Services Division

## Event Coordination

Upon the completion of a signed contract, the Alamodome will assign an Event Coordinator to your account. This individual will become your primary contact throughout the event planning and execution process. The Event Coordinator is responsible for the coordination of the event requirements with the departments, technicians, and contractors of the Alamodome. The Event Coordinator is also your day-of-event contact, and will oversee all facility operations under the supervision of upper management.

## Other functions of the Event Services Division

- Staffing and cost estimates
- Floor plan and coordination and approval with the San Antonio Fire Department
- Shipping and receiving assistance
- Production and technical specifications
- Preliminary invoice

## Production Meetings

The Event Coordinator will conduct a production meeting prior to your load-in and arrival to review any specifications and arrangements regarding the event. All facility divisions and contractors will participate to ensure all aspects of the event have been thoroughly reviewed. Prior to the start of the event, a pre-event briefing will be held with all department supervisors. Your participation in both of these sessions is encouraged.

# Box Office & Ticketing

## **Ticketmaster**

The Alamodome is a Ticketmaster exclusive facility. The selling of tickets through any other ticket agency, or by any other means outside of Ticketmaster is prohibited. Additionally, tickets may not be sold on a consignment basis without the approval of the Box Office Manager. You should contact the Box Office Manager to discuss ticket sales on Ticketmaster. Please note that typically, once all information is received to build an event on Ticketmaster, the creation process will take up to four (4) business days to complete. Please keep this in mind when planning for your event on sale. Once an event is on sale, any changes made to the event such as added discounts, pricing changes, artist changes, ticket header changes, etc., will be approximately three (3) business days to complete. Again, please keep this in mind when planning your event.

## **Box Office Hours**

The Southwest Box office is open Monday thru Friday from 10am - 4pm and as necessary for events. On event days, the box office typically opens at least two hours before the event. Hours may vary based on projected ticket sales and/or promoter requests.

## **Box Office Staffing**

The Alamodome will provide staffing during your event. The number of sellers will be determined by the Box Office Manager and is based on the size of the event, historical data, and the public interest in the event during the days leading up to the event itself.

## **Settlement**

Event settlement is conducted by the City of San Antonio Fiscal division. Please contact your Event Coordinator to determine the timing of your event settlement.

## **Group Sales**

The Alamodome does not offer group sale tickets. Coordinating group sales is a responsibility of the promoter. Group Sales for the Alamodome are typically outsourced. For more information or to learn about our preferred group sales vendor, please contact your Event Coordinator.

# Building Policies

## Camera/Recording Policy

Video and audio recorders are not permitted inside the Alamodome unless approved in advance by show or building management.

## Children's Entry policy

All guests ages 2 and over are required to have a ticket for admission, unless otherwise specified.

## Re-Entry Policy

The Alamodome has a no re-entry policy. Re-entry on the same ticket is prohibited.

## Prohibited Items

For safety reasons, prohibited items include but are not limited to:

- Alcohol
  - Animals (except service animals to aid guests with disabilities)
  - Artificial noisemakers or noisemaking devices of any kind
  - Balloons (helium, air filled or deflated)
  - Balls or any object that can be used as a projectile
  - Cameras with professional lenses longer than 3", GoPros, video recorders and mono/tripods
  - Fireworks, Smoke Bombs
  - Folding chairs, stools or other seating devices
  - Illegal substances
  - Laser pointers
  - Outside food and beverage and containers of any kind (except for guests with medical and dietary needs)
  - Personal carts, wagons or other large rolling devices
  - Poles or sticks of any kind, including selfie-sticks
  - Prohibited bags include, but are not limited to, the following: all purses, bags or containers larger than a 5.5" x 8.5" small clutch bag, coolers, briefcases, backpacks, fanny packs, cinch bags, luggage of any kind, computer bags and camera bags. (**See Clear Bag Policy**)
  - Sealed packages of any kind
  - Signs or flags larger than 3' x 2'
  - Smoking, e-cigarettes or vapes
  - Segways, skateboards and hoverboards
  - Weapons of any kind (firearms, knives, etc.)
  - Unmanned aircraft systems/radio controlled model aircraft
  - Any other item(s) determined by event management to be dangerous or inappropriate will not be allowed
- Prohibited items per event are subject to change without notice.**

## Public Policies

- No soliciting.
- Tobacco & smoke free environment. Smoking locations are on the East and West 50 doors on the Plaza Level.
- Re-entry is not allowed.
- There is always the possibility of the use of pyro, strobes, lasers, and confetti during an event.

- The Alamodome prohibits scalping and the resale of tickets on property.
- If an item is revealed during a search, patrons may dispose of the item or they may return the item to their vehicle. The Alamodome does not safeguard any personal belongings or other items.

## **Animals**

Animals are not permitted in the Alamodome with the exception of service animals. All events displaying live animals must notify the Alamodome in writing prior to the event date. All animals must have health documents as required by federal, state and municipality statuses.

## **Balloons**

Helium balloons are not allowed in any part of the facility, either for display, for sale or as gifts. For decoration purposes, air-filled balloons may be used. The Licensee is responsible for informing exhibitors of this policy. The facilities reserve the right to remove any helium-filled balloons at Licensee's expense.

## **Deliveries**

Event deliveries may be made to the Alamodome a maximum of three days in advance of and during an event. Please address all deliveries to your Event Coordinator and include the name of the Event.

All deliveries are to be shipped to 100 Montana Street, San Antonio, TX 78203. Once received, deliveries will be stored in the Alamodome's Inventory Center. Contact your Event Coordinator with a list of known deliveries prior to their arrival. The Alamodome is not responsible for items that may be lost or damaged during shipment.

## **Recycling**

The Alamodome pursues conservation policies in regards to energy, water and recycling whenever possible. Since 2006, the Alamodome has created several "green" initiatives to reduce the number of chemicals used and to conserve water and energy. The facility recycles various items and materials including glass, plastic, aluminum.

## **Service Contractors**

Certain services provided within the facility are on an exclusive or preferred (non-exclusive) basis. Please contact your Event Coordinator for more information.

## **Building Policies Continued...**

### **Posters & Signage**

With prior approval by the Event Coordinator, event- related and professionally printed banners, posters, and signs may be displayed in various locations inside and outside of the facility. Licensee is responsible for acquiring the measurements needed for signage. Under no circumstances should any posters, signs, etc. be attached to walls, doors, or windows. Licensee is responsible for the removal of all such posters, signs, etc., and any cleaning of residue left by item, at the conclusion of their event. No decorative or structural items may be attached to or hung from any overhead beam, column, handrail, utility pipe, exterior wall, or fence without prior written approval. The Licensee will be charged for the labor and materials required for removal resulting from violation of this policy.

### **Stickers, Decals, & Adhesives**

The use of any type of adhesives on any facility owned surface is strictly prohibited. Licensee is responsible for the labor and materials required for cleanup and repair resulting from violation of this policy.

### **Tape**

The use of double-sided tape on any facility surface is strictly prohibited. Painters or decorators tape is permitted on surfaces with the exception of stained concrete. Licensee is responsible for ensuring all tape is removed at the conclusion of the event. Licensee is responsible for the labor and materials required for cleanup and repair resulting from violations of this policy.

## **Public Safety Policies**

The Alamodome is committed to providing a safe and secure environment for employees, performers, promoters and guests. The Alamodome offers the following security and safety services:

- Security Control and Public Safety phone line staffed 24 hours a day. (210.207.3680).
  - Physical security surveillance and control
  - Medical personnel coordination for patron and performer first aid and EMT/ALS team services.
- Ambulances dedicated for event personnel can also be coordinated upon request.

# SAN ANTONIO ALAMODOME

## CLEAR BAG POLICY

---

### APPROVED BAGS



5.5" x 8.5"  
CLUTCH PURSE

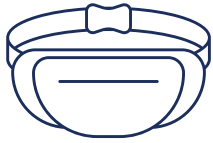

12" x 6" x 12"  
CLEAR FANNY PACK

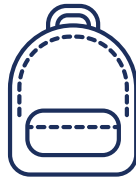

12" x 6" x 12"  
CLEAR BACKPACK



12" x 6" x 12"  
CLEAR PLASTIC BAG



3" x 4"  
CLUTCH PURSE

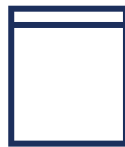

1 GALLON  
CLEAR PLASTIC  
STORAGE BAG

---

### PROHIBITED BAGS



BACKPACK



PURSE



CAMERA BAG



FANNY PACK



SEAT CUSHION



PRINTED PATTERN BAG



BINOCULAR CASE

FOR MORE INFORMATION VISIT: [ALAMODOME.COM](http://ALAMODOME.COM)

Revised 12/4/24

## **Bomb Sweeps**

Bomb sweeps are arranged for each event by the Alamodome Public Safety Manager. Bomb sweeps are conducted by the San Antonio Police Department's and Bomb and K9 Unit. For many events, especially those that require consistent Loading Dock access, deliveries, equipment transport, drop-offs, etc., the K9 team will stay on throughout the event. For more information, please contact the Alamodome Public Safety Manager.

## **Event Command Center**

The Alamodome will have an Event Command Center in operation during your event. This command center serves as the central operational headquarters for all events. Representatives from Alamodome divisions as well as police and fire will be monitoring all activities and communications during the event.

## **Law Enforcement**

The San Antonio Police Departments Off-Duty Employment Unit (SAPD ODEU) is the exclusive provider for law enforcement and overnight security staffing, at the Alamodome. Licensee is responsible for procuring law enforcement services for each event from SAPD ODEU, which will be coordinated by the Alamodome Public Safety Manager. No event staff, other than SAPD ODEU officers, are allowed to physically intervene with anyone within the facilities. The staffing level is determined solely by the SAPD ODEU, based on event specifications and event history.

## **Medical Services**

First-Aid and ambulance services may only be obtained from the Alamodome's contracted event provider. These services will be coordinated by the Alamodome Public Safety Manager. Athletic trainers and/or specialist may be coordinated by the client with the vendor of their choosing.

## **Peer Security**

Supplemental event security staff may only be obtained from the Alamodome's contracted event provider. Peer security will be coordinated by the Alamodome Public Safety Manager.

## **Security Screenings**

Walk-through metal detectors and/or hand wands are used for the safety of all staff, guests, and performers for all events. As previously mentioned, the Alamodome enforces a clear bag policy. Bags will be searched prior to entering the facility.

## Weapons Policy

The Alamodome complies with federal and state laws and city ordinances regarding the lawful carrying and possessing of weapons within Department facilities. ("LTC" – License to Carry) Illegal weapons are prohibited at all times.

As a contracting client paying for the private use of facility and event related space, you are responsible for designating your event to be considered "Weapons Prohibited" (banning all weapons) or "Weapons Permitted" (allowing hand guns to be lawfully carried per state concealed and open carry legislation).

If requesting a "Weapons Prohibited" event designation, the Alamodome will provide the necessary Texas Penal Code signage (Texas Penal Code Sections 30.05, 30.06 [c][3][A], 30.07 [c][3][A] and 46.03). Placement of such signage will be posted during the period of the event and will remain in place until the end of the fully executed term shown in this License Agreement, unless specifically requested to be removed.

AS A GOVERNMENT OWNED BUILDING, ALAMODOME STAFF IS NOT AUTHORIZED TO MAKE ANY DECISIONS ON WHETHER TO POST THE APPLICABLE SIGNAGE FOR ANY EVENT.

## Alamodome ACP & Gate Map

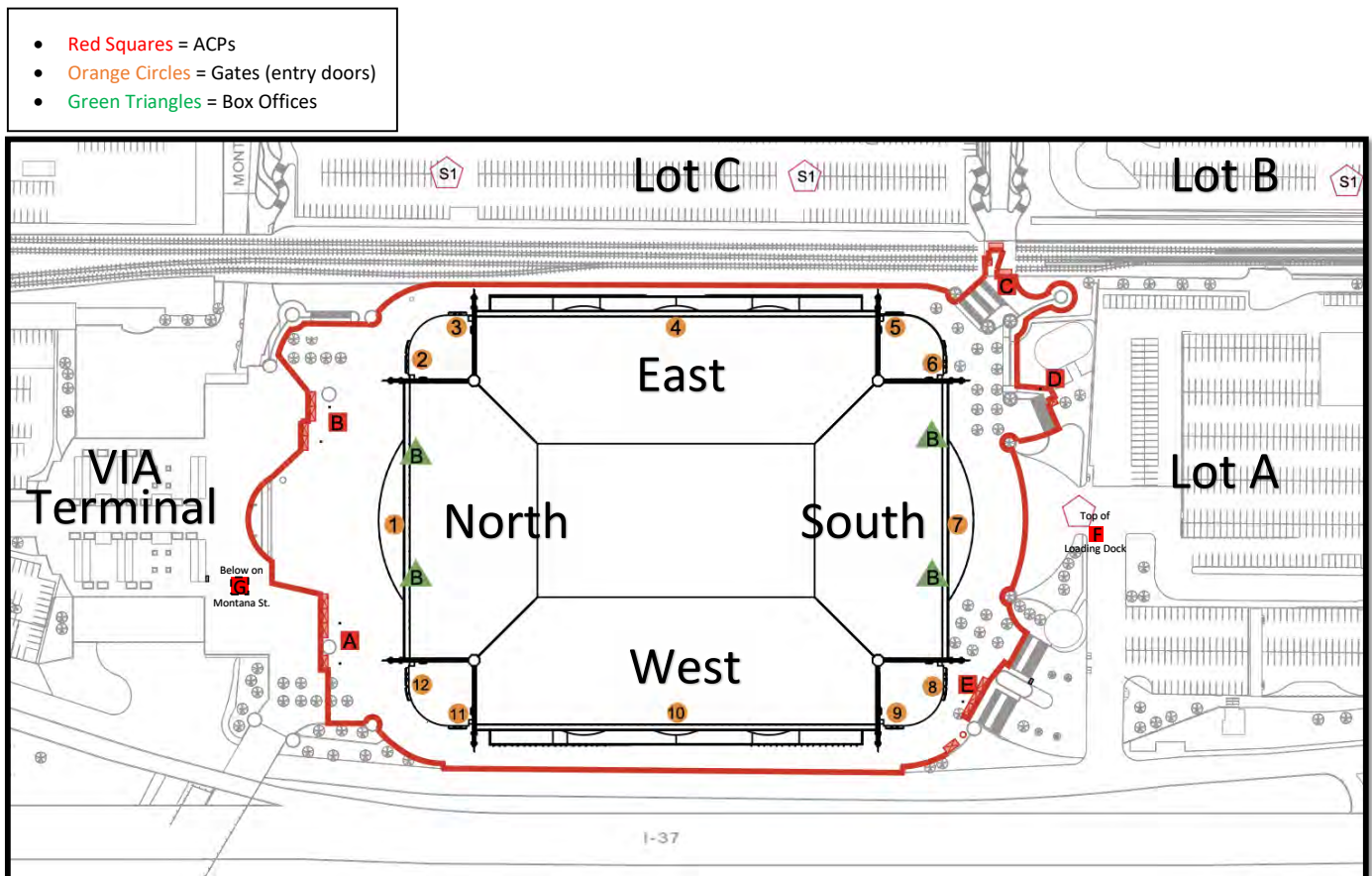

# Guest Services

## Entrances

The Alamodome has (12) possible sets of Entrance Gates and (174) individual doors for event use:

- Gate 1 (27) North Glass Doors
- Gate 2 (18) Northeast Metal Doors
- Gate 3 (10) East- Northeast Metal Doors
- Gate 4 (8) East Glass Doors
- Gate 5 (10) East- Southeast Metal Doors
- Gates 6 (14) Southeast Metal Doors
- Gate 7 (27) South Glass Doors
- Gates 8 (14) Southwest Metal Doors
- Gate 9 (10) West- Southwest Metal Doors
- Gate 10 (8) West Glass Doors
- Gate 11 (10) West- Northwest Metal Doors
- Gates 12 (18) Northwest Metal Doors

## Passenger Elevators

- (2) on the North, (2) on the East, (1) on the South and (2) on the West.
- Capacity: 4,500 lb. weight limit and/or 10 persons

## Escalators

- (2) from North Plaza Level to Field Level.

## Restrooms

Restrooms are located on all levels and are equipped to meet the needs of all guests, including those with disabilities. Family restrooms are available on all general public access levels near the North and South elevators.

## Automatic Teller Machines (ATMs)

ATM Machines are located on all general public access levels.

## Information Desks

The Alamodome offers two Information Desks on Plaza Level, one on the North Plaza and one on the South Plaza Level, and three on Club Level, North, East and West. Staff at these locations are available to assist guest with facility and event questions.

## Lost & Found

During the event, found items can be brought to the North Information Desk to be claimed. At the close of the event, any unclaimed items will be stored in Security Control.

# Services for Guest with Disabilities

The Alamodome strives to provide an equitable experience for all patrons and is fully compliant with the Americans with Disabilities Act (ADA). If you are expecting attendees with special needs please speak with your Event Coordinator so that all necessary accommodations can be made in advance. Please see some of the accommodations and services we provide for guest with disabilities below:

## **Assistive Listening Devices**

Assisted Listening Devices are available at the North and South Information Desks, on the Plaza Level.

## **Accessible Parking and Drop-Off**

Accessible parking is located in Lot A, off of the Northbound IH-37 access road, between César E. Chávez Blvd. and Montana St. The Alamodome provides 127 accessible spaces that are available on a first come, first served basis for vehicles with a valid State issued placard (blue or red) or license plate. Accessible parking is subject to the event parking rates. Complimentary drop-off and pick-up for patrons with disabilities is available in Lot A, as well as an accessible ramp leading to the Plaza level. .

## **Accessible Seating**

Accessible seating areas are available on our Plaza, Club and Upper Levels. The Alamodome offers 272 standard accessible seating spaces, where mobility devices may be used, as well as 312 companion seats available. The amount of seats available for sale for each event are dependent on each individual event's configuration and specifications.

## **Guest Assist Program**

The Alamodome operates a golf cart in parking Lot A, where the accessible spaces are located, to assist guests from the parking area to the accessible ramp location.

## **Wheelchair Transport Services (Interior)**

Wheelchairs and Wheelchair Operators are available to assist patrons from the entry Gates to their seats, once they have entered the Alamodome. The wheelchairs may not be brought outside the building.

# Advertising & Promotion

## Outdoor Marquee

The Alamodome's Marquee is located in Parking Lot A and is visible from Interstate 37 and the surrounding area. The Alamodome will run between one and twenty graphics in a sequence, similar to a slideshow, featuring the upcoming venue schedule. Event graphics may be run up to 45 days prior to the show date. Graphics must be full color, 600 x 480 pixels, and are best if "saved for web" JPEGs at 100% size in RGB color mode. Resolution is 72dpi. All graphics must be sent in the correct size formatting.

No sponsorship logos can be used unless part of the event's name. The following is an example:

- YES: Valero Alamo Bowl
- NO: Alamo Bowl Presented by Valero

## Social Media

The Alamodome promotes events taking place via social media on Facebook, X, and Instagram. Specific promoter request for advertising will be handled on a case-by-case basis. Ticket promotions, giveaways, and other fan interaction promotions are welcome and encouraged.

Follow the Alamodome:

- Facebook: [facebook.com/Alamodome](https://facebook.com/Alamodome)
- X: @Alamodome
- Instagram: @alamodomesa

## Outdoor Marquee

The Alamodome's Marquee is located in Parking Lot A and is visible from Interstate 37 and the surrounding area.

- The Alamodome will run one graphic in a sequence, similar to a slideshow, per event. Graphics may be run up to 45 days prior to an event.
- Graphics must be full color, 600 x 480 pixels, and are best if "saved for web" JPEGs at 100% size in RGB color mode. Resolution is 72dpi.

## **Press Release**

Please include a press release along with your graphics consisting of artist, ticket and event information and a description of the event for the information page.

## **E-Blasts & Promotional Announcements**

Marketing questions concerning E-Blasts and Promotional Announcements should be directed to our Marketing Manager.

## **Website**

We will promote your event via [www.alamodome.com](http://www.alamodome.com). The website requires a minimum of four graphics:

- Homepage Feature Graphic: 776px X 475px
- Primary Homepage Graphic: 776px X 475px
- Event Detail Graphic: 578px X 515px
- Thumbnail Graphic: 382px X 340px

## **Alamodome Logo**

Licensee or exhibitors may not use Alamodome logos for any purpose without the prior approval. The use of Alamodome logos in any brochures, advertisements, or other publicity must be approved in advance. For questions or concerns regarding please contact our Marketing Manager.

## **Star Partner Promotions**

The Alamodome has a number of Star Partners that are entitled to the following during all events:

- H-E-B and Pepsi will each will receive a minimum of two minutes and thirty seconds of features on the digital ribbon boards during the event. They will also receive a minimum of four (4) feature executions on the LED video scoreboards pre, during event.

# Food & Beverage

Legends Global is the exclusive Food and Beverage provider at the Alamodome. A leader in delivering high quality food & beverage options, the Legends Global team will work with you create and customize an all-star menu for you and your guests.

## **Concessions**

The Alamodome features a wide range of concessions that make dining at the Alamodome a treat.

Concessions feature flavors and brands such as Johnny Rocket's, D&D Kettle Corn, Igloo Frozen Drinks, Kona Ice, Maui Wowi Hawaiian Smoothies & Frozen Cocktails, Big Bib Barbecue, Earl Abel's, and Los Barrios.

## **Catering/Premium Services**

Whether personal or corporate, large or small, from field level, suite level or on the upper deck, Savor Black Tie is your in-house caterer at the Alamo dome. At Savor Black Tie we take pride in the work we do and the service we provide. Our years of experience, qualified staff, excellent services coordination and planning skills, can guarantee your full satisfaction. You can count on our Premium Service Department to deliver impeccable food services; our experts in the culinary field can accommodate all your menu options. We are confident we can deliver the highest quality of service possible and hope for the opportunity to serve you. If you're planning a corporate event, convention, fundraiser, organizational or personal event, count on us to ensure that your special day is also a memorable one that you and your guests will enjoy.

## **Food & Beverage Policies**

- Unless contractually agreed upon, all backstage and special event food and beverage will be arranged and provided by our exclusive food and beverage partner. Those wishing to use another provider must agree to and abide by the catering buy-out terms and conditions.
- Approved vendors may offer sampling of products during the event. Samples may be no larger than 4 ounce and each vendor must obtain a permit. Vendors can contact the SAFD by phone (210) 207-0013 to inquire about the permit requirements.
- Unless notified otherwise, food and beverages brought onto the parking lot areas is permissible. Food and beverages from outside sources cannot be brought into the Alamodome building itself.

- Alcoholic beverages may be served within the facilities during certain events. Licensee is responsible for obtaining off-duty San Antonio Police Department (SAPD) officers at any event in which alcohol is being served or sold. The final number of officers is determined solely by the SAPD Off-Duty Employment Unit (ODEU) based on event requirements.
- The service or sale of alcohol to minors is prohibited by law. We ID every time. Any concerns regarding alcohol outside of these parameters need to be addressed directly with your alcohol provider.



# PRODUCTION

**In this section, you will find information regarding AV specifications for the video walls and ribbon boards, equipment, personnel, event power locations, rigging, roof grid and catwalks, fire safety requirements, permitting and our labor rate card.**

# A/V Specs for Video Walls and Ribbons

**\*All graphics and videos must be submitted one week prior to event**

## Corner Video Walls and Center Hung boards

### HD Video Commercials & Moving Graphics:

- 1080i or 1080p / 29.97fps (ONLY)
- .mov or mpg4
- NO 24 FPS COMMERCIALS
- NO FLASH FILES/ FLASH ANIMATION

### Stills:

- .png (if alpha needed) / .jpeg (If alpha not needed)
- Width: 1920 / Height: 1080
- Resolution: 72 Pixels/Inch
- Color Mode: RGB Color / 8 bit
- Color Profile: Don't Color Manage
- Pixel Aspect Ratio: Square Pixels
- Use these settings in Photoshop

## 360 Ribbon Boards

### Motion Graphics:

\*The ribbon boards are divided into 4 separate sections. Please keep this in mind when creating a continuous 360 ring.

- Width: 9088px / Height: 64px
- Pixel aspect ratio: Square Pixels
- Frame Rate: 59.94 fps (ONLY)
- .mov or mpg4
- NO FLASH FILES/ FLASH ANIMATION

### Stills:

\*The ribbon boards are divided into 4 separate sections. Please keep this in mind when creating a continuous 360 ring.

- .jpeg / .targa / .png
- Width: 9088px / Height: 64px
- Resolution: 72 Pixels/Inch
- Color Mode: RGB Color / 8 bit
- Color Profile: Don't Color Manage
- Use these settings in Photoshop

# ALAMODOME RIBBON BOARD LAYOUT

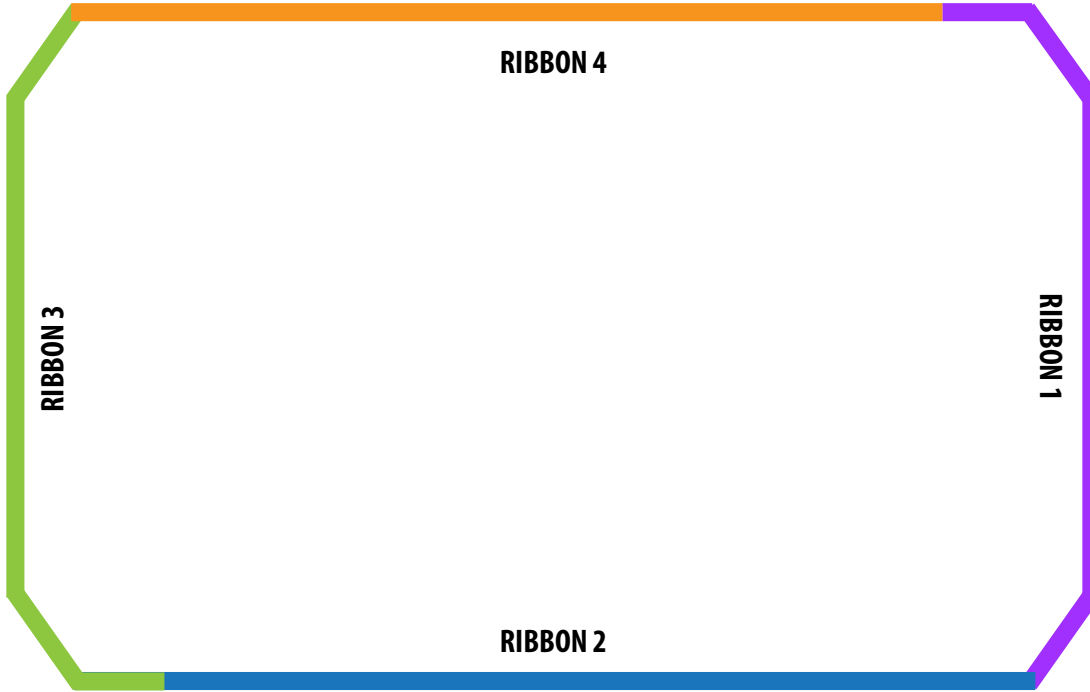

← NORTH

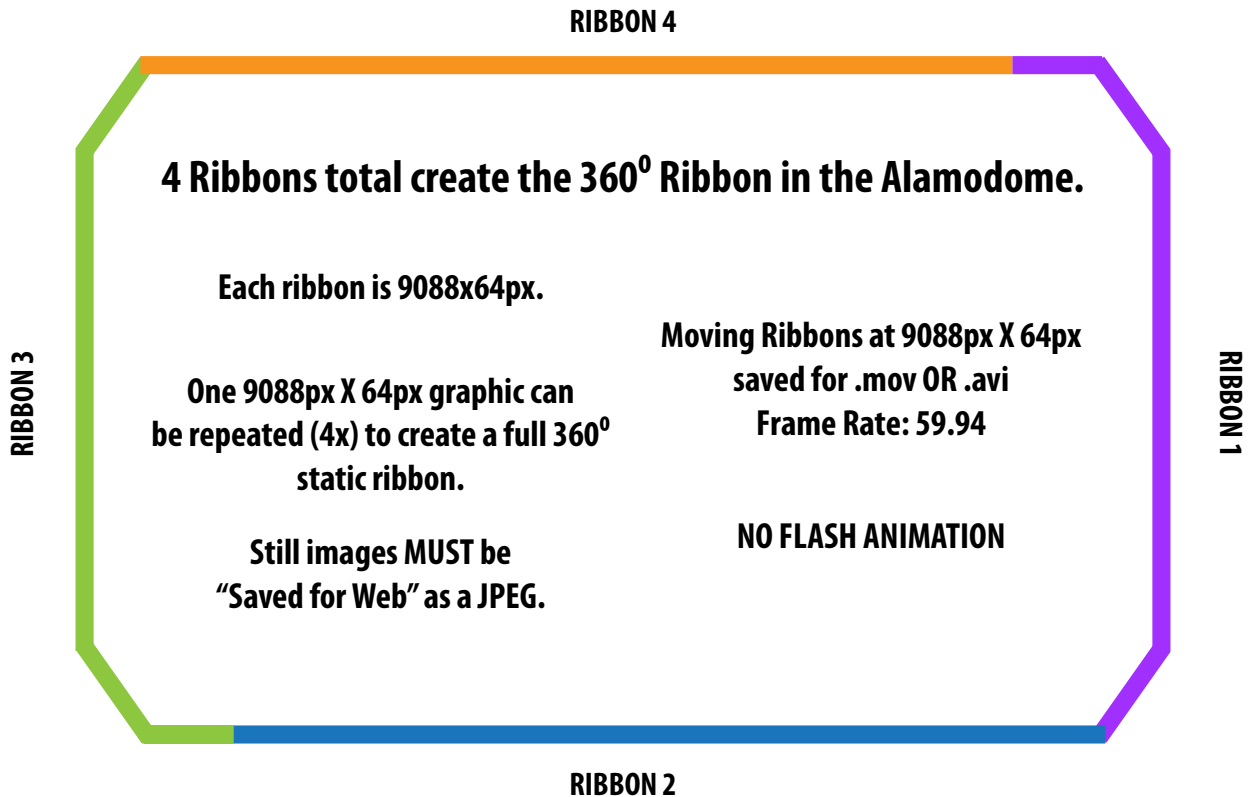

← NORTH



# ALAMODOME STATIC RIBBONS WITH SCOREBOARD MUST BE DESIGNED AS FOLLOWS

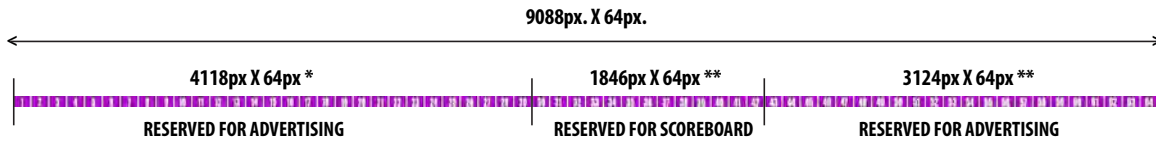

\* BLOCKS 1 - 29 RESERVED FOR ADVERTISEMENT • 4118px X 64px



\*\* BLOCKS 30 - 42 RESERVED FOR SCOREBOARD • 1846px X 64px



\*\*\* BLOCKS 43 - 64 RESERVED FOR ADVERTISEMENT • 3124px X 64px

ALL ribbons are numbered 1- 64  
Each number block is 142px.  
142px. X 64(blocks) = 9088px.



## ALAMODOME STATIC RIBBONS WITH SCOREBOARD EXAMPLES



**DESIGNERS NOTE:** FILE IMAGE MUST FILL ENTIRE RIBBON (9088X64) DO NOT CUT OFF DESIGN AT BLOCKS 30-42.  
JPEG SHOULD BE EXPORTED IN RGB COLOR MODE, 9088px X 64px AT 100% FILE SIZE AT 72 dpi. BEST IF "SAVED FOR WEB".  
DO NOT ARRANGE ANY LOGO WITHIN RESERVED SCOREBOARD AREA.

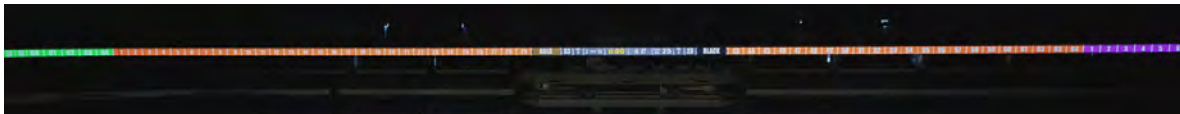

RIBBON 4 EXAMPLE ■



# Equipment & Personnel

The Alamodome has Video Production Equipment and Personnel that can be provided at an additional cost per event. All Equipment and Personnel must be requested at least two weeks prior to the scheduled event.

## **Cameras:**

- 3 -- Ikegami HDK-65C/BDT Cameras with XJ80X8.8B/P01-DSS with full camera support and CCU's 1080i
- 3 -- Ikegami HDK-65C/BDT Cameras with HJ24EX7.5B with full camera support and CCU's 1080i
- 1 -- Ikegami HDK-65C/BDT wireless Camera with HJ14eX4.3B with full camera support and CCU's 1080i

## **Instant Replay:**

- 1 -- Evertz DreamCatcher Replay System 8 channels, pan and zoom, High frame rate camera support

## **Ribbons & Graphics:**

- 2 -- Ross Dual Channel Xpression Studio CG

## **Switcher**

- 1 -- Ross Acuity 4ME, 32 input switcher

## **Digital Recorder:**

- 4 -- AJA 4K/Ultra HD and 2K/HD Recorder/Player

# Event Power Availability

## 6,770 Total Amps, 225A Total Amps 480V

### Cables & Ramps In-House

- (40) Yellow Jackets/Cable Ramp
- (8) 3ft ADA Cable Ramps
- (24) 1 1/2ft ADA Cable Ramps
- (4 Sets) 150' Show Cable
- (2 Sets) 100' Show Cable
- (1 Set) 75' Show Cable
- (1 Set) 50' Show Cable
- 

### Stadium Lighting

- LED Musco Lighting

### Upper Seating Lighting

- 1500W Metal Halide

### East Loading Dock:

- (3) 200A 3Phase/208V Disconnects w/ Cam-Loks
- (6) 30A 3Phase/208V - (1) 30A 3Phase 208V  
(5 disconnects being used for lift station, charging or other).

### West Loading Dock:

- (3) 200amp 3Phase/208V Disconnects w/ Cam-Loks
- (3) 30A 3Phase 208V & (3) 50A 3Phase 208V

### South East Tunnel:

- (2) 600amp 3phase/208v
- (1) 400 amp 3phase/208v
- (1) 100 amp 3phase/208v

### East 50-Yard Line

- (1) 600 amp 3phase/208v
- (1) 400 amp 3phase/208v

### West 50-Yard Line:

- (1) 600 amp 3phase/208v
- (1) 400 amp 3phase/208v

### Catwalk Disconnect – Center Stadium:

- (1) 800 amp 3phase/208v Disconnects w/ Cam-Loks

### Catwalk Disconnect – North Stadium Area:

- (1) 800 amp 3phase/208v Disconnects w/ Cam-Loks

### Quad C Electrical Room

- (1) 600A 3Phase 208V w/ Cam-Lok Tails

# Power Map

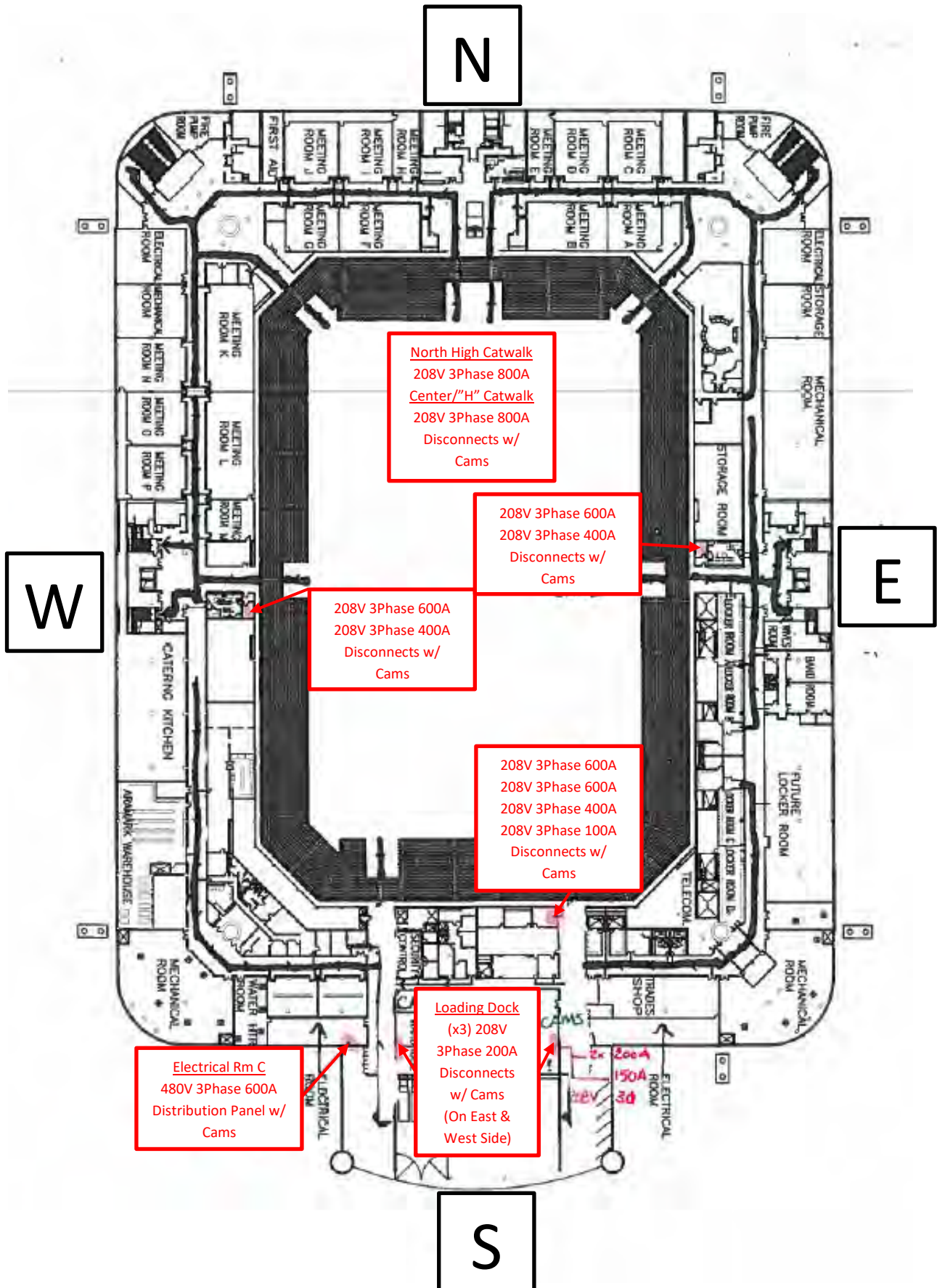

North High Catwalk  
 208V 3Phase 800A  
 Center/"H" Catwalk  
 208V 3Phase 800A  
 Disconnects w/  
 Cams

208V 3Phase 600A  
 208V 3Phase 400A  
 Disconnects w/  
 Cams

208V 3Phase 600A  
 208V 3Phase 400A  
 Disconnects w/  
 Cams

208V 3Phase 600A  
 208V 3Phase 600A  
 208V 3Phase 400A  
 208V 3Phase 100A  
 Disconnects w/  
 Cams

Electrical Rm C  
 480V 3Phase 600A  
 Distribution Panel w/  
 Cams

Loading Dock  
 (x3) 208V  
 3Phase 200A  
 Disconnects  
 w/ Cams  
 (On East &  
 West Side)

# Rigging

The rigging of items weighing less than 250 lbs. can be performed by your general services contractor (decorator), or another qualified provider. The rigging of items that weigh over 250 lbs. must be reviewed and approved by a representative of the Alamodome's exclusive rigging company. A certified rigger must hang everything from the chain hoist/motor up to the ceiling.

## Roof, Sound, & Lighting Grid Measurements

- Beams: 10'-6" wide center to center
- Catwalk: 160' from floor
- Bowed Truss Steel (Bottom): 120' from floor
- Bottom of Steel: 164-4" from floor
- Top of Steel: 171' from floor
- Arena North Concert Grid: 60' x 80' 30pt. grid that supports 162k max weight
- Center Floor Concert Grid: 60' x 80' 30pt. grid that supports 162k max weight
- Center Floor Scoreboard Grid: 38' x 57' 18pt. grid that supports 90k max weight
- South Floor Concert Grid: 60' x 80' 35pt. grid that supports 162k max weight

## Seating Unit

Interval Unit Weight:

- 42' unit weighs 26,250 lbs. plus 13,440 lbs. of seating = 39,690 lbs.
- 36' unit weighs 22,500 lbs. plus 10,080 lbs. of seating = 32,580 lbs.

## Stagehands

Licensee is responsible for utilizing a certified stagehand for requirements including rigging, lighting, sound, etc. Stagehand requirements can be coordinated through Upstage Center Inc, the preferred provider of rigging service.

## Floor Weight Capacities

Stadium floor concrete: 3500 PSI and 6000 PSI concrete

Ice Sheets: 1100 PSF

The inside loading dock: 1100 PSF

South plaza over the loading dock: 11000 PSF

# Roof Grid & Catwalk

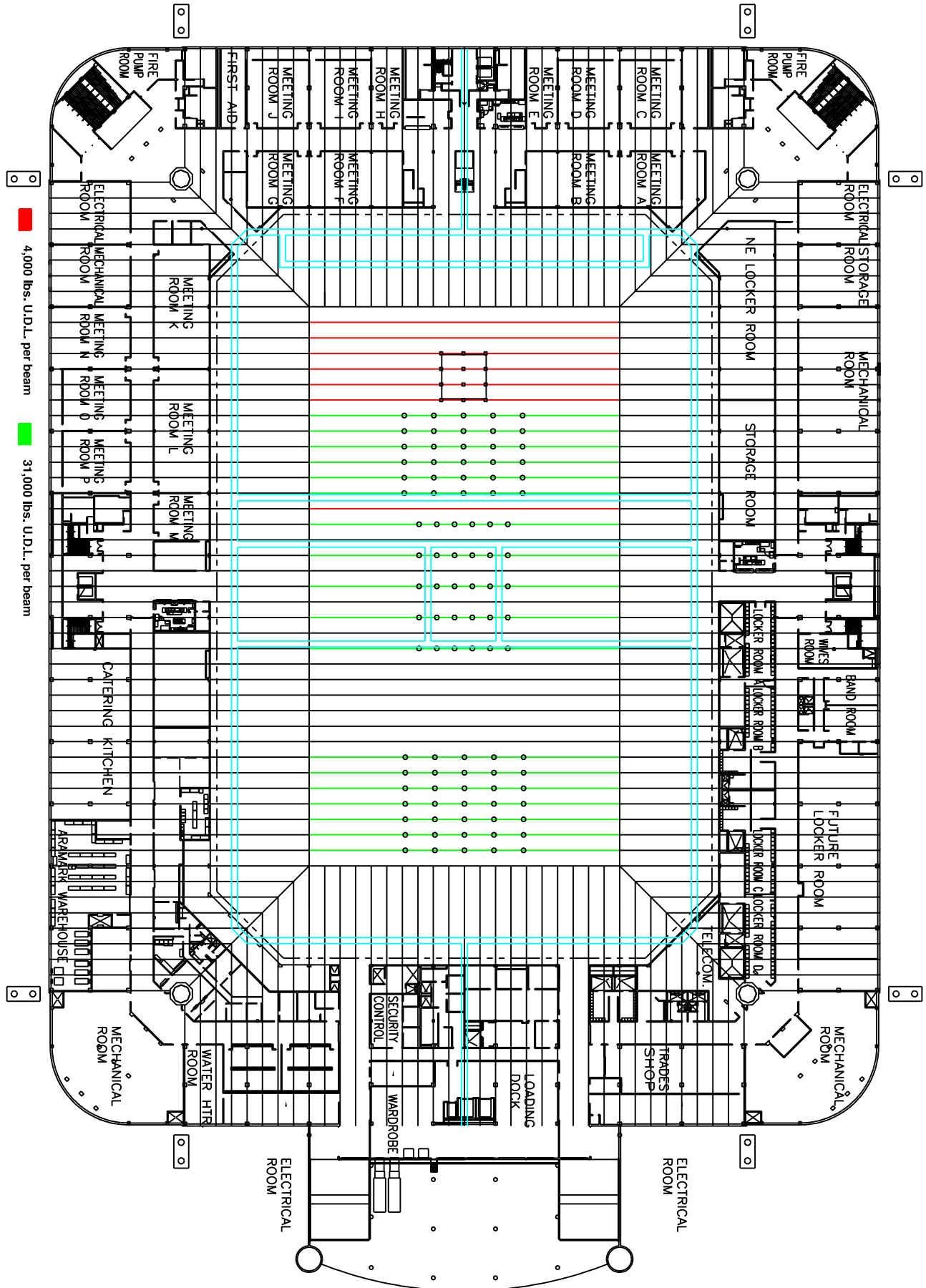

# Fire Safety Requirements

## **Pyrotechnics**

Licensee and all contractors must comply with the San Antonio Fire Department's Fire Regulations for Public Assembly Occupancies. A permit is required for the use of pyrotechnics during events. Please contact Jose A. Rios with SAFD by phone, (210) 207-3695, or by email at [Joe.Rios@sanantonio.gov](mailto:Joe.Rios@sanantonio.gov) for permitting inquiries.

## **Automobiles**

Personally-Owned Vehicles (POV's) may not be driven into the facility without permission from your Event Coordinator and may only be operated inside the building for loading and unloading of large equipment. Vehicles may be displayed with prior approval from the City of San Antonio Fire Marshal.

It is the responsibility of the Licensee to ensure that exhibitors are aware of these guidelines.

## **Floor Plans**

The Alamodome and San Antonio Fire Marshals must approve all seating prior to on sale. The blocking of aisles, exits or corridors of any type is prohibited.

## **Electrical Wiring**

Electrical cords will be grounded and UL listed. Extension cords may be used provided they are plugged directly into an outlet or an approved power strip and are rated for the intended power use.

## **Standby Inspector**

If determined necessary by the San Antonio Fire Department, a standby fire marshal will be present during the event. Any costs for this additional requirement will be the responsibility of the promoter.

## **Indoor Structures and Enclosed Tenting**

All Indoor enclosed structures are required to have operational smoke detectors and fire extinguishers. All structures are subject to approval by the fire marshal.

# Permitting

The Development Services Department for the City of San Antonio has outlined the following process for permitting. Items possibly needing permitting include but are not limited to generators, tents and stages. Please contact the Development Services Department to ensure you complete proper permitting.

Jeremy Camarillo  
Development Services Manager  
(210) 207-0003  
Jeremy.Camarillo@sanantonio.gov

## **The following items should be submitted to the above contact:**

### 1. Temporary Use Application:

a. <https://docsonline.sanantonio.gov/FileUploads/DSD/TemporaryUsesApplication.pdf>

### 2. Please provide two hard copies of the site plan of the event

- a. Identify all tents
- b. Identify all stages/temporary event structures
- c. Identify location of generators

### 3. A city registered Texas Master Electrician will need to secure an electrical permit for the generators

a. [https://docsonline.sanantonio.gov/FileUploads/DSD/DSD\\_Electrical\\_Application.pdf](https://docsonline.sanantonio.gov/FileUploads/DSD/DSD_Electrical_Application.pdf)

### 4. Please provide total square footage, number of stories, occupant load, floor plan for

- a. All tents
- b. All stages/temporary event structures

### 5. Please confirm that a safety and traffic plan have been put into place

### 6. Please provide two hard copies of the Texas engineered drawings, specs, fire rating fabric certificate, and anchoring details for tents over 5,000 sq. ft. (two hard copies)

### 7. Please provide two hard copies of the Texas engineered drawings, specs, and bracing details for temporary event structures (Stages, scaffolding, rigging, platforms, and visual effect structures over 400 sq. ft.)

### 8. Inspections will include Building, Fire, and Electrical

- a. Building will require a third party inspection report in addition to CoSA building inspection for any items outlined in bullet points 5 & 6



# LABOR RATE CARD

<b>PUBLIC SAFETY (per hour)</b>			
Security Manager	\$37.50	SAPD Supervisor (3 Hours Min.)*	\$67.73
Security Supervisor	\$29.00	SAPD Sup. (3 Hr. Min.)* <b>Effective 4/1/26</b>	\$70.04
Security Guard	\$26.00	SAPD Officer (3 Hours Min.)*	\$56.61
In-House Security Officer	\$22.50	SAPD Off. (3 Hr. Min.)* <b>Effective 4/1/26</b>	\$58.48
Medical Services ALS/BLS*	\$63.10 / \$55.07	SAPD Parking at \$15.00 per Officer	
Ambulance/ Muleulance (per hr.)	\$150.00/ \$89.00	SAFD	\$82.40
<b>* Higher rate applies to first hour of service with lower rate being applied to all hours there after.</b>			
<b>EVENT SERVICES (per hour)</b>			
Event Supervisor	\$65.00	Guest Service Manager	\$28.00
Event Coordinator		Guest Service Attendant	\$25.00
Event Command Security Dispatch	\$31.00	Event Command GS Dispatch	\$25.00
<b>BOX OFFICE (per hour)</b>			
Rental Fee	\$500.00/day	Box Office Administrator/Manager	\$50.00
Security Deposit	\$500.00/use	Box Office Supervisor	\$35.00
		Ticket Seller	\$25.00
<i>* Also applies to HBGCC and Carver Community Center</i>			
<b>OPERATIONS AND MAINTENANCE (per hour)</b>			
Operations Supervisor	\$50.00	Head Turf Manager	\$75.00
Operations Staff	\$35.00	Equipment Operator	By quote
HVAC System Operator	\$50.00	Electrician	\$50.00
Plumber	\$50.00		
<b>OTHER (per hour)</b>			
Parking Supervisor	\$35.00	Cleaning Supervisor	\$35.00
Parking Attendant	\$25.00	Cleaning Attendant	\$29.00
<b>AV AND TELECOMMUNICATIONS EQUIPMENT &amp; SERVICES (per unit/per event)*</b>			
<b>AV SERVICES AND EQUIPMENT RATES *AR = Advanced Rate; SR = Show Rate</b>			
In House Closed Circuit Monitors	\$600.00	Additional Closed Circuit Channel	\$100.00
60" Color Television	\$350.00		
<i>Rate Card continues to next page...</i>			



# EQUIPMENT RATE CARD

AV AND TELECOMMUNICATIONS EQUIPMENT & SERVICES <i>(Continued)</i>			
<b>BROADCAST SUPPORT</b>			
Camera Hookup – Triax	\$195.00	Fiber Connectivity	By quote
ENG Hookup – 1 Video, 2 Audio	\$120.00	Fiber Connectivity to Transmission Carrier	\$75.00
Audio/Video Interconnectivity	\$185.00	House Light Operator	\$35.00
<b>CATV/DMX SERVICES</b>			
Cable Television	\$75.00		
<b>INTERCOM</b>			
Wired Intercom	\$50.00	Wireless Intercom	\$75.00
<b>MICROPHONES &amp; DIRECT BOXES</b>			
Basic Mic. with Cable & Stand	\$25.00	Wireless Headset Mic (must include wireless system direct box)	\$25.00
Wireless Mic System	\$75.00		
<b>MISCELLANEOUS</b>			
Park and Power	\$250.00/Truck		
<b>P. A. PACKAGES</b>			
Small (8 channel power mixes, 2ea. speakers w/stands, 2ea. wired mics w/stands and all cables)	\$350.00	Medium (8 channel power mixes, 4ea. speakers w/stands, 4ea. wired mics w/stands and all cables)	\$500.00
Large (16 channel mixer, 2ea. large speakers w/stands, 2ea. floor monitors, 1 ea. stereo amplifier, 6ea. wired mics w/stands and all cables)	\$1,000.00	Active Press Box (16 channel 12M/4L)	\$50.00
Arena PA Sound System (L-Acoustics Line Array System)	\$3,600.00	Stadium PA Sound System (L-Acoustics Line Array System)	\$3,600.00
Audio patch Fee	\$30.00	Audio Snake Box and Fan - Out (100' – 12 channels)	\$50.00
Single Analog Line	\$250.00	Com Drop	\$20.00
Digital Multi-Service Line 2-Lines	\$275.00	Ringdown with Instruments	\$250.00
Additional Lines on Multi Line Service	\$35.00	Dedicated T1 Line	By quote
Dry Pair Connection – SBC D Marc	\$200.00	Dry Pair Connection – Internal	\$100.00
Voice Mail	\$15.00	Telephone Technician Services	\$90.00/hour
Long Distance Restriction per line	\$5.00	Dedicated Internet Line	\$950.00
Video Pass Through	By quote	Video Production	By quote
360 VIDEO RING	\$3,600.00	Temp Phone (De-) Activation	\$15.00
HD VIDEO Walls (4)	\$1,250.00/each	Domestic Long Distance per minute	\$0.40
<i>Rate Card continues to next page...</i>			



# EQUIPMENT RATE CARD

EQUIPMENT RENTAL (per unit/per event)			
Basketball Floor	By quote	Pipe & Drape	\$25.00
8' Bike Rack	\$25.00	Podium	\$35.00
Camera Platform	\$400.00	Project Screen	\$35.00
Chairs	\$2.50	Riser	\$45.00
Stanchion	\$25.00	Shore Power	\$200.00
Dry Erase Board	\$25.00	Sports Turf	By quote
Easel	\$25.00	Spotlight	\$500.00
Extension Cord	\$25.00	Stage (60' x 40')	\$3,500.00
Forklift (6 Ton)	By quote	Table (8' x 30")	\$15.00
Ice Floor	By quote	Table (8' x 18")	\$15.00
Inertia Barricade	\$2,000.00	Table Dolly	\$20.00
Lost Room Key	\$100.00	Yellow Jacket Cable Ramp	\$25.00

Published rates are subject to change. To confirm current costs, please contact Alamodome  
 Booking: Phone; (210) 207-3752 • Email; [Toryn.Jones@sanantonio.gov](mailto:Toryn.Jones@sanantonio.gov) • Online form;  
[www.alamodome.com](http://www.alamodome.com)



SAN ANTONIO  
**ALAMODOME**

---

**ONE TEAM**



**100 MONTANA ST. SAN ANTONIO, TEXAS 78203**