

# ALAMODOME

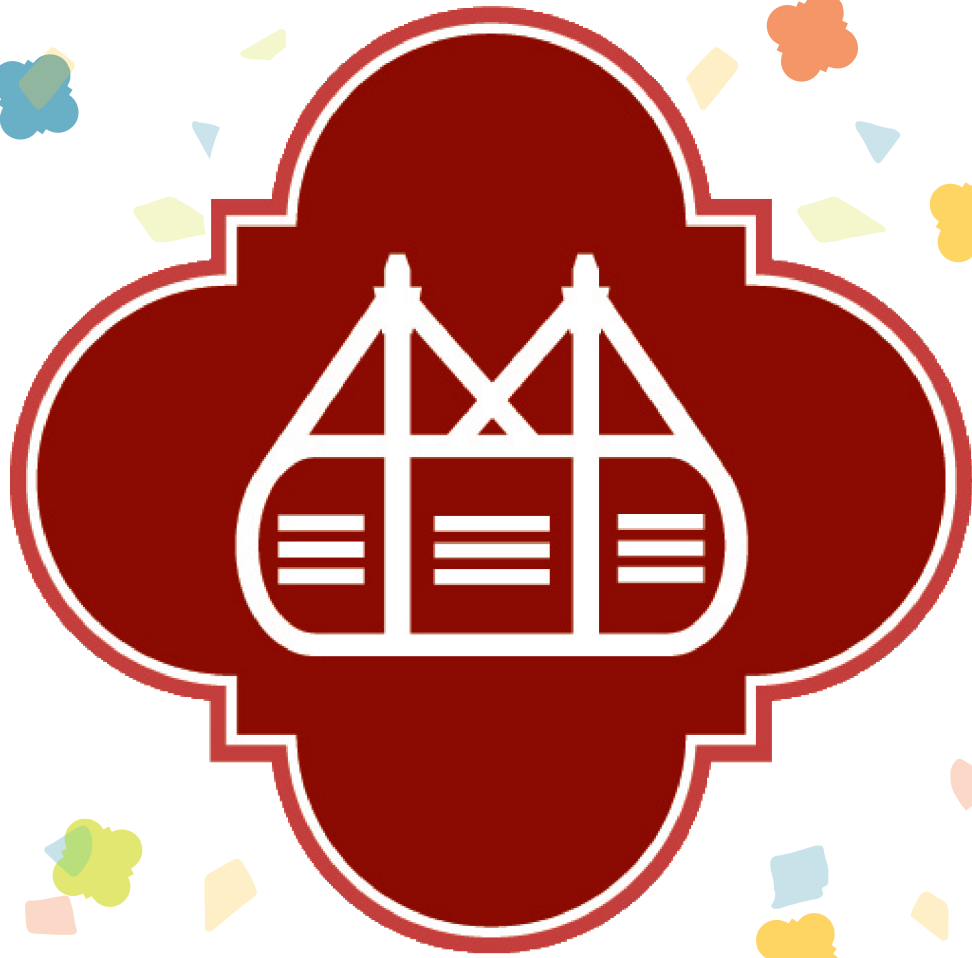

# EVENT PLANNING GUIDE

# TABLE OF CONTENTS

Facility Overview .....	3
Staff Directory.....	4
About San Antonio .....	6
Building .....	9
Configurations	
Locker Rooms, Backstage Rooms, Meeting Rooms	
Press Box & Coaches/Broadcast Booths	
Suites	
Hospitality Spaces	
Parking	
Load In/Out	
Planning & Services .....	25
Booking & Services	
Event Services	
Box Office & Ticketing	
Building Policies	
Open & Concealed Carry	
Safety & Security	
Guest Services	
Advertising & Promotion	
Production .....	39
A/V Specs	
A/V Equipment & Personnel	
Power Map	
Rigging and Load Capacities	
Roof Grid & Catwalk	
Fire Safety Requirements	
Permitting	
Current Equipment & Labor Rates	

# FACILITY OVERVIEW



## The Alamodome

Opened in 1993, the Alamodome has consistently cast its spotlights on an incredible range of entertainment and sporting events. The Alamodome is a versatile facility with over 160,000 square feet of flexible space, hosting an average of 150 events per year. The Alamodome is a city-owned and operated multipurpose facility located in the heart of downtown San Antonio.

### Architect:

- Populous
- Marmon Mok
- W.E. Simpson Company

### General Contractor:

- Huber, Hunt & Nichols

### Owner & Operator:

- City Of San Antonio

### Tenants:

- San Antonio Sports
- UTSA Roadrunners Football
- Valero Alamo Bowl
- San Antonio Commanders

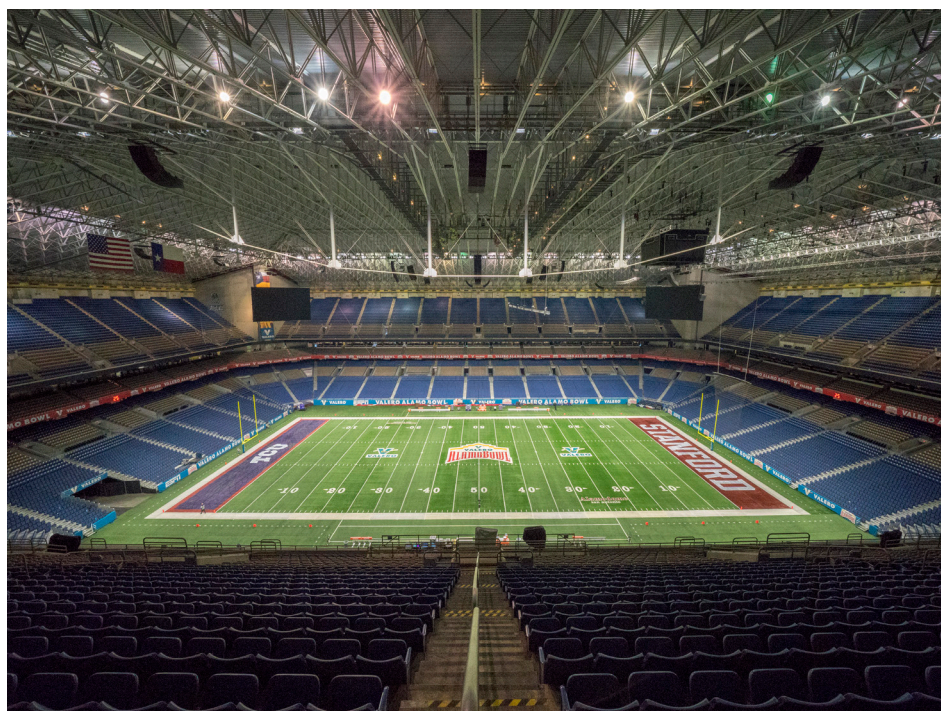

# STAFF DIRECTORY



**Address**  
100 Montana Street  
San Antonio, TX 78203

**Main Switchboard**  
(210) 207.DOME

**Main Fax Number**  
(210) 207.3636

**Website**  
Alamodome.com

**Social Media**  
Facebook.com/Alamodome  
Twitter: @Alamodome  
Instagram: @AlamodomeSA

## Administration

Stephen Zito, Interim General Manager  
Stephen.Zito@sanantonio.gov | 210.207.3605

Rachel Arredondo, GM Administrative Assistant  
Rachel.Arredondo@sanantonio.gov | 210.207.3602

Darius Dunn, Operations & Maintenance Facility Mgr.  
Darius.Dunn@sanantonio.gov | 210.207.3603

## Booking Services

Michael Flores, Booking Services Manager  
Michael.Flores@sanantonio.gov | 210.207.3620

Chynnon Albeck, Sr. Administrative Assistant/Suites  
Chynnon.Albeck@sanantonio.gov | 210.207.3650

## Box Office

David Welsh, Box Office Manager  
David.Welsh@sanantonio.gov | 210.207.3635

Amanda Yruegas, Box Office Assistant  
Amanda.Yruegas@sanantonio.gov | 210.207.3609

## Event Services

Paula Hobbie, Event Services Manager  
Paula.Hobbie@sanantonio.gov | 210.207.3671

Estela Cantu, Sr. Event Services Coordinator  
Estela.Cantu@sanantonio.gov | 210.207.3607

Andrea Robson Event Services Coordinator  
Andrea.Robson@sanantonio.gov | 210.207.3636

## Finance

Jennifer Ann Galindo, Financial Analyst  
Jennifer.Galindo@sanantonio.gov | 210.207.3751

Bobby Vela, Financial Analyst  
Robert.Vela2@sanantonio.gov | 210.207.5760

## Maintenance & Operations

Eric Duncan, Department Facility Coordinator  
Eric.Duncan@sanantonio.gov | 210.207.3608

Tom McAfee, Building Maintenance Manager  
Thomas.Mcafee@sanantonio.gov | 210.207.3754

James Story, Sr. Building Maintenance Supervisor  
James.Story@sanantonio.gov | 210.207.3667

Alethea DeHoyos, Building Maintenance Officer  
Alethea.Dehoyos@sanantonio.gov | 210.704.6114

Venancio Medina, HVAC Supervisor  
Venancio.Medina@sanantonio.gov | 210.207.3668

Herman Ortiz, Horticulturist Supervisor  
Herman.Ortiz@sanantonio.gov | 210.207.3682

Silvia Ceja, Inventory Control  
Silvia.Ceja@sanantonio.gov | 210.207.6367

Jo Ann Reyes, Administrative Assistant  
Joann.Reyes@sanantonio.gov | 210.207.3631

## Marketing

Andrea DeLaune, Marketing Manager  
Andrea.Delaune@sanantonio.gov | 210.207.3642

Rick Garcia, Marketing, Media & Graphic Coordinator  
Rick.Garcia@sanantonio.gov | 210.207.3626

Michelle Brady, Customer Service Specialist  
Michelle.Brady@sanantonio.gov | 210.704.6330

Joshua Linares, Graphic Designer  
Joshua.Linares@sanantonio.gov | 210.207.3691

Rosie Lomas, Sr. Customer Service Representative  
Rosie.Lomas@sanantonio.gov | 210.207.3663

## Risk Management

Pedro Reyes, Safety Coordinator  
Pedro.Reyes@sanantonio.gov | 210.207.3641

## Security & Parking

Robert Blackman, Security Guard  
Robert.Blackman@sanantonio.gov | 210.207.3649

Rudy Zamorano, Security Guard  
Rudy.Zamorano@sanantonio.gov | 210.207.3649

Frank Anaya Jr., Parking Supervisor  
Frank.Anaya@sanantonio.gov | 210.207.3753

## Technical Services

Jason Bippert, Telecommunications Manager  
Jason.Bippert@sanantonio.gov | 210.207.3629

Manuel Corales, Audio Video Production Supervisor  
Manuel.Corales@sanantonio.gov | 210.207.3640

Ben Sturgis, Sr. Audio Video Technician  
Benjamin.Sturgis@sanantonio.gov | 210.207.3623

Katie White, Sr. Audio Video Technician  
Katie.White@sanantonio.gov | 210.207.3618

Carlos Diaz, IT Technician  
Carlos.Diaz@sanantonio.gov | 210.207.3643

## Fire Department

Kelly Turner, Captain  
Kelly.Turner@sanantonio.gov | 210.207.3695

## Police Department

Anthony Powers, Sergeant  
Anthony.Powers@sanantonio.gov | 210.207.7020

# About San Antonio...

## Airport

Located in north central San Antonio, the San Antonio International Airport (SAT) is only 8.5 miles from the downtown business district - about a 15-minute drive - which is unusual for major metropolitan areas.

## Public Transportation

Getting around San Antonio and downtown is a breeze with our wide selection of transportation options, including the VIVA by VIA service, River Taxi, Cabs, Uber, and Lyft.

## Driving

### FROM IH-35 SOUTH

Take US-90 East to New Braunfels Street exit, north on New Braunfels to Commerce Street, west on Commerce Street to Cherry Street, south on Cherry Street and into lots.

### COMING FROM IH-10 EAST

Use Hackberry Street exit, north on Hackberry to Cesar Chavez Blvd., west on Cesar Chavez Blvd. to Cherry Street, North on Cherry Street and into lots.

### COMING FROM IH-10 WEST

Use IH-35 north to New Braunfels Street exit, south on New Braunfels to Commerce Street, West on Commerce Street to Cherry Street, south on Cherry Street and into lots.

### COMING FROM IH-37 SOUTH

Use Cesar Chavez Blvd. exit, east on Cesar Chavez Blvd. to Cherry Street, north on Cherry Street and into lots.

### COMING FROM US 281 NORTH

Use Cesar Chavez Blvd. exit, east on Cesar Chavez Blvd. to Cherry Street, north on Cherry Street and into lots.

## Hotels

With over 14,000 hotel rooms in downtown San Antonio there are endless lodging options within walking distance of the Alamodome. A Visit San Antonio representative can assist with all travel needs. See [VisitSanAntonio.com](http://VisitSanAntonio.com) for more information.

## Recreation/Attractions

Home to the legendary Alamo and world-famous River Walk, San Antonio offers a wide range of exciting and unique activities. San Antonio has five theme parks, working ranches, rivers to float, and 300 days of sunshine perfect for golfing one of our 50 courses. In San Antonio there is something for everyone.

## Dining

While San Antonio is famous for Tex-Mex, you'll also find traditional Mexican cuisine along with German, French, English and Italian eateries. The venues are just as varied as the types of cuisine they serve. From white tablecloth to savory food trucks to genuine steakhouses and BBQ joints, there's always something new and different to try.

## Shopping

According to [Forbes.com](http://Forbes.com), San Antonio is one of America's top ten best cities to shop. With several malls and local shops displaying handmade items, you can take home both the culture of San Antonio and the latest fashion trends.

## Hospitals

Multiple medical facilities are available within two miles of the Alamodome (Baptist Medical Center, The Children's Hospital of San Antonio), as well as a short six mile drive to a major medical complex of several hospitals with nationally recognized physicians and research facilities.

# SAN ANTONIO DOWNTOWN AREA

# OVERVIEW



For more information on hotels, restaurants, events and sightseeing tours, come by the Official Visitor Information Center at 317 Alamo Plaza or call toll free 800-447-3372. Located directly across from the Alamo. OPEN SEVEN DAYS A WEEK (CLOSED: New Year's Day, April 24th - Battle of Flowers Parade, September 30th, Thanksgiving Day and Christmas Day).

VisitSanAntonio.com







# BUILDING

The Alamodome is a unique facility with the flexibility to host a wide variety of events. The following are examples of the more common configurations, however any plan can be adjusted to meet specific event needs.

## Capacities Per Configuration

Full Stadium- Football & Soccer: 63,682

Full Stadium- Concert: 43,672

Full Stadium- In the Round: 73,086

Arena Basketball: 31,853

Arena Concert: 26,345

Illusions Theater: 11,602

## Capacities By Level

Plaza Level: 29,647

Club Level: 6,232

Suite Seats: 806

Upper Level: 27,605

# FULL STADIUM-FOOTBALL/SOCCER

63,682

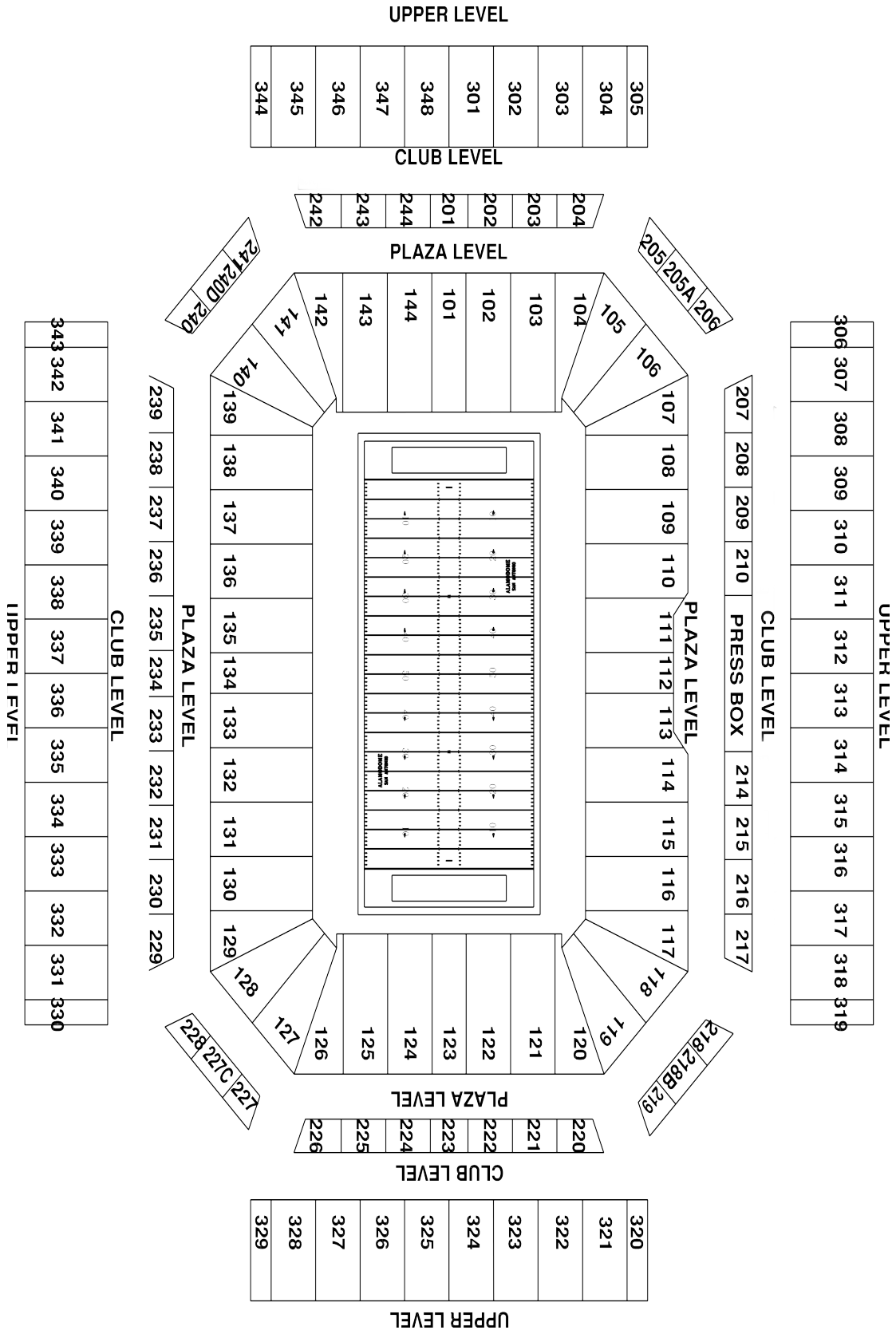

# FULL STADIUM CONCERT-END STAGE

43,672 (without floor seats)

.....  
 \*The estimated capacity includes the typical number of floor seats (8,000) for this configuration. Capacities based on your needs may vary.

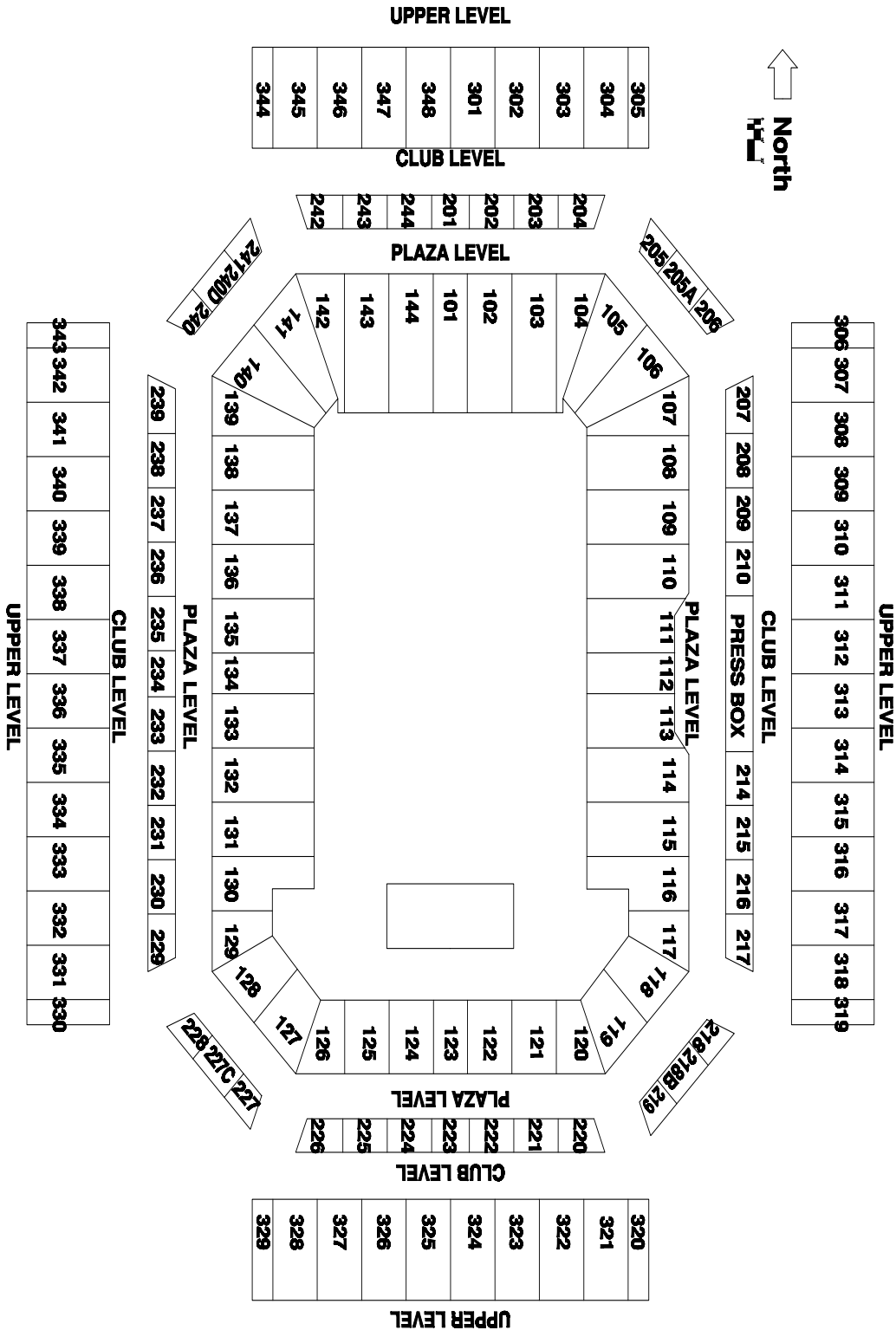

# ARENA CONCERT

26,345

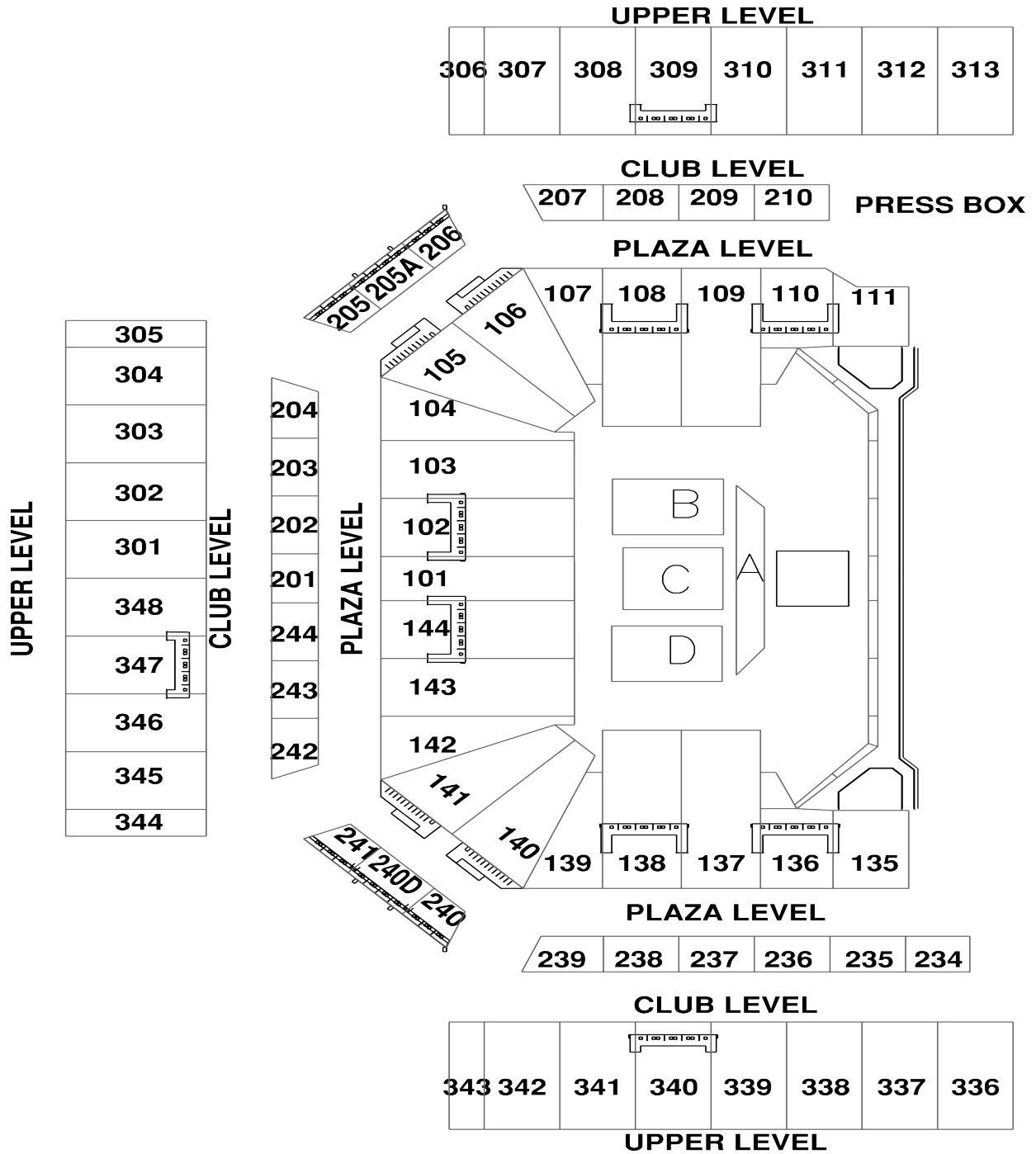

# FULL STADIUM-IN THE ROUND

70,000\*

.....

\*The estimated capacity includes the typical number of floor seats (8,000) for this configuration. Capacities based on your needs may vary.

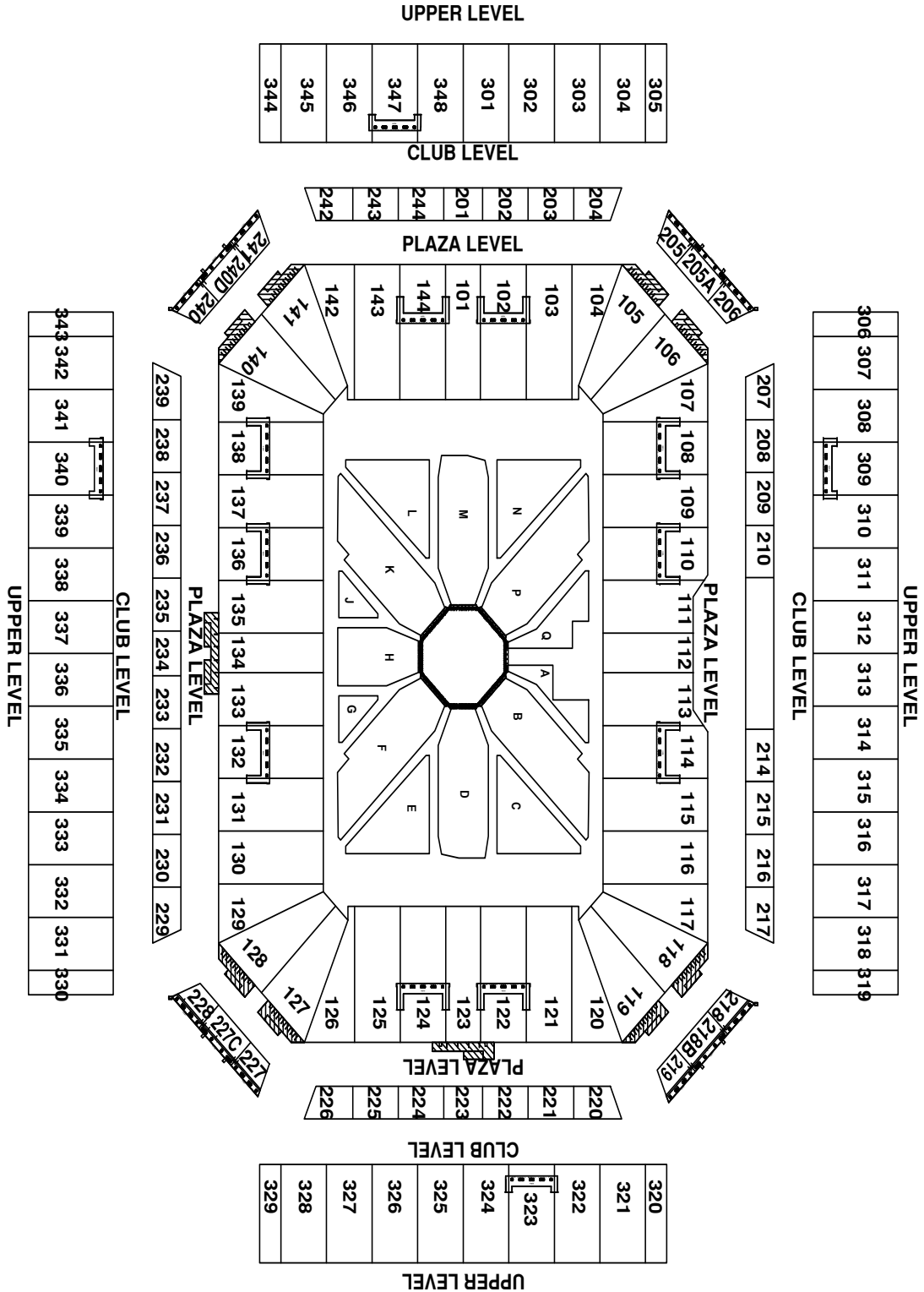

# ILLUSIONS THEATER

11,602

.....

The Illusions Theater is the Alamodome's newest specialty venue. Featuring a state-of-the-art curtain system and LED lighting, The Illusions Theater has a uniquely intimate setting. With a base set for 4,000 seats, the venue offers unparalleled versatility and can configure for up to over 11,000 guests.

## UPPER LEVEL

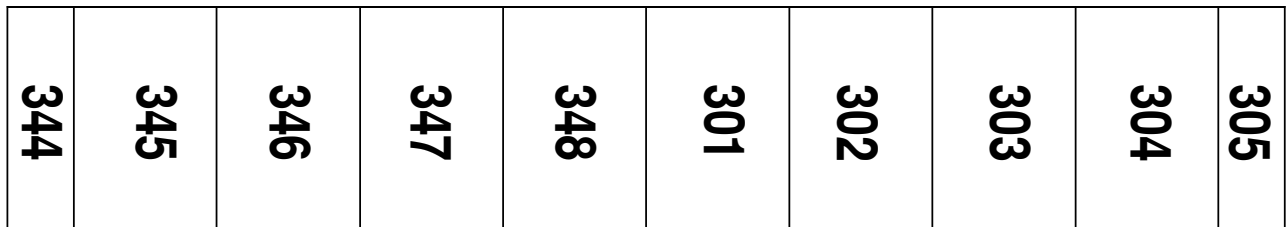

## CLUB LEVEL



## PLAZA LEVEL

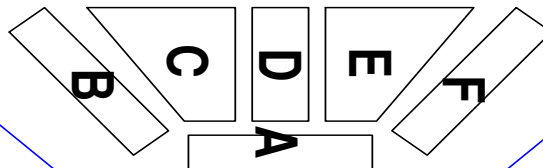
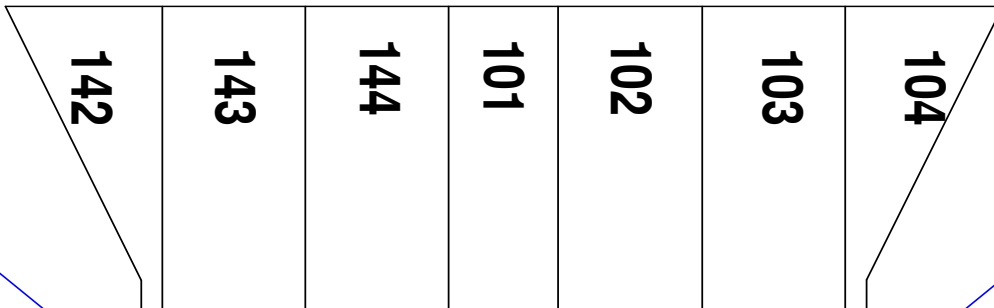

# TRADESHOW

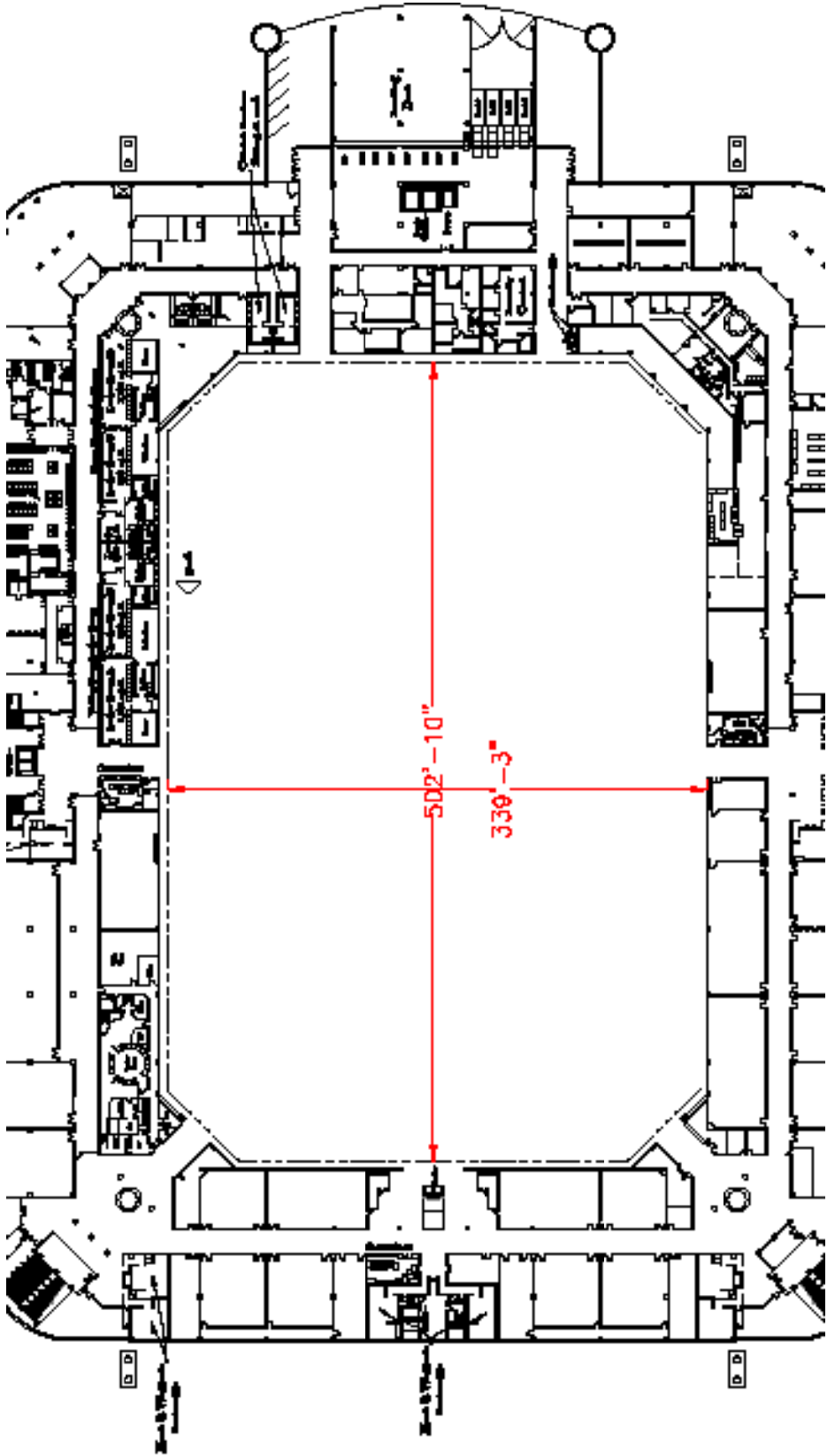

**BUILDING**

## Locker Rooms Backstage Rooms

Room Name*	Square Feet	Restrooms	Showers	Lockers	Additional Features
Locker Room A	1,071	X	X	32	Head Coach Locker Room w/shower
Locker Room B	897	X	X	39	Head Coach Locker Room w/shower
Locker Room C	897	X	X	40	Head Coach Locker Room w/shower
Locker Room D	1,174	X	X	33	Head Coach Locker Room w/shower
NE Locker Room	5,300	X	X		Head Coach Locker Room w/shower
Home Team Locker Room	7,500	X	X	132	Equipment Room, Training Room, Coaches Lounge, Head Coach Office w/Shower
W Officials Locker Room	500	X	X	13	
E Officials Locker Room	500	X	X	13	
X-Ray Room	391				
Visitors Interview Booth	180				Broadcast Connections
Home Interview Booth	180				
Production Office	1,700				Air wall divider equipped
North Dressing Room	166	X	X		Part of Production Office Compound
South Dressing Room	166	X	X		Part of Production Office Compound
Green Room	977	X			

\*Please note that Locker Rooms A/B and C/D are air wall equipped and may be combined. Production Office is air wall equipped and may be split in half.

## Meeting Rooms

Meeting Room	Gross Sq. Ft.	Approx. Room Size	Theatre	Classroom	Banquet	Ceiling Height
A	1,506	37' x 42'	104	52	63	12'6"
B	2,338	37' x 63'	156	78	94	12'6"
A&B	3,844	37' x 105'	260	130	157	12'6"
C	1,830	41' x 45'	123	62	74	12'6"
D	1,830	41' x 45'	123	62	74	12'6"
C&D	3,660	41' x 90'	246	124	148	12'6"
F	2,338	37' x 63'	156	78	94	12'6"
G	1,506	37' x 42'	104	52	63	12'6"
F&G	3,844	37' x 105'	260	130	157	12'6"
I	1,830	41' x 45'	123	62	74	12'6"
J	1,830	41' x 45'	123	62	74	12'6"
I&J	3,660	41' x 90'	246	124	148	12'6"
K	3,059	37' x 83'	205	103	123	12'6"
L	3,059	37' x 83'	205	103	123	12'6"
K&L	6,118	37' x 166'	410	206	246	12'6"
M	1,149	37' x 32'	79	40	48	12'6"
N	2,159	41' x 54'	148	74	89	12'6"
O	1,826	41' x 45'	123	62	74	12'6"
P	1,826	41' x 45'	123	62	74	12'6"
N/O/P	5,811	41' x 144'	394	198	237	12'6"



## Press Box

### Details

- Seating for 150 persons
- Located on the East 50-yard line Mezzanine level
- An additional room measuring 16'x41' is also available
- Four (4) Auxiliary Press areas can be created throughout the Mezzanine level, each seating approximately 30 persons.

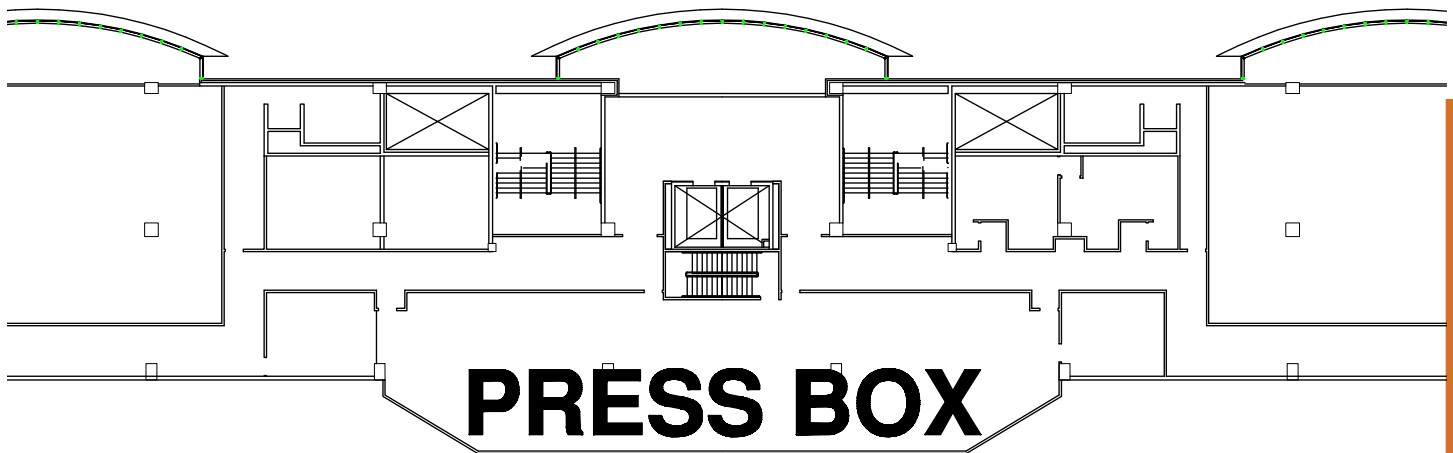

**BUILDING**

## Coaches/Broadcast Booths

### Details

- 9 total booths available (A-I)
- Located directly above the Press Box on the East 50-yard line Club level
- Inner stairwell to Press Box for easy access

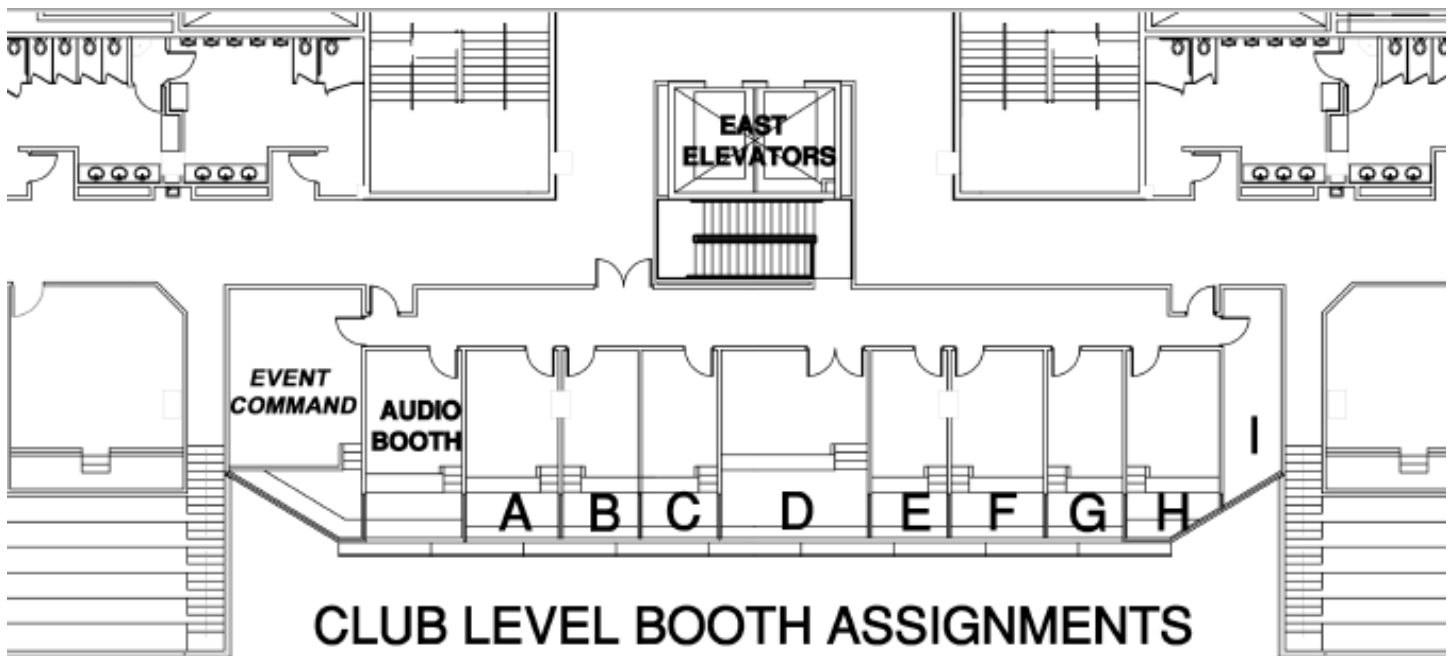

# Suites

Our Club Level includes 52 private rooms, with seating for up to 12, 14, 15, or 16. Suites have been renovated to enhance the elegant design and provide the most up to date technology.

## Suite Packages Include

- Parking
- Customized Menus
- Exclusive Catering Prices

Delicious food, refreshing beverages and outstanding service are only a few of the amenities that make your experience unforgettable. In a luxury suite at the Alamodome you will have the best seats for concerts and sporting events while leaving a lasting impression on your valued clients, employees, family and friends.

In addition to the private spaces, be sure to ask about our open air terrace suite space. Terrace suites overlook the Dome floor or field and can be personalized to accommodate 20-100 guests for an event or gathering.

For information on leasing an Alamodome suite, please email [suitesales@alamodome.com](mailto:suitesales@alamodome.com).

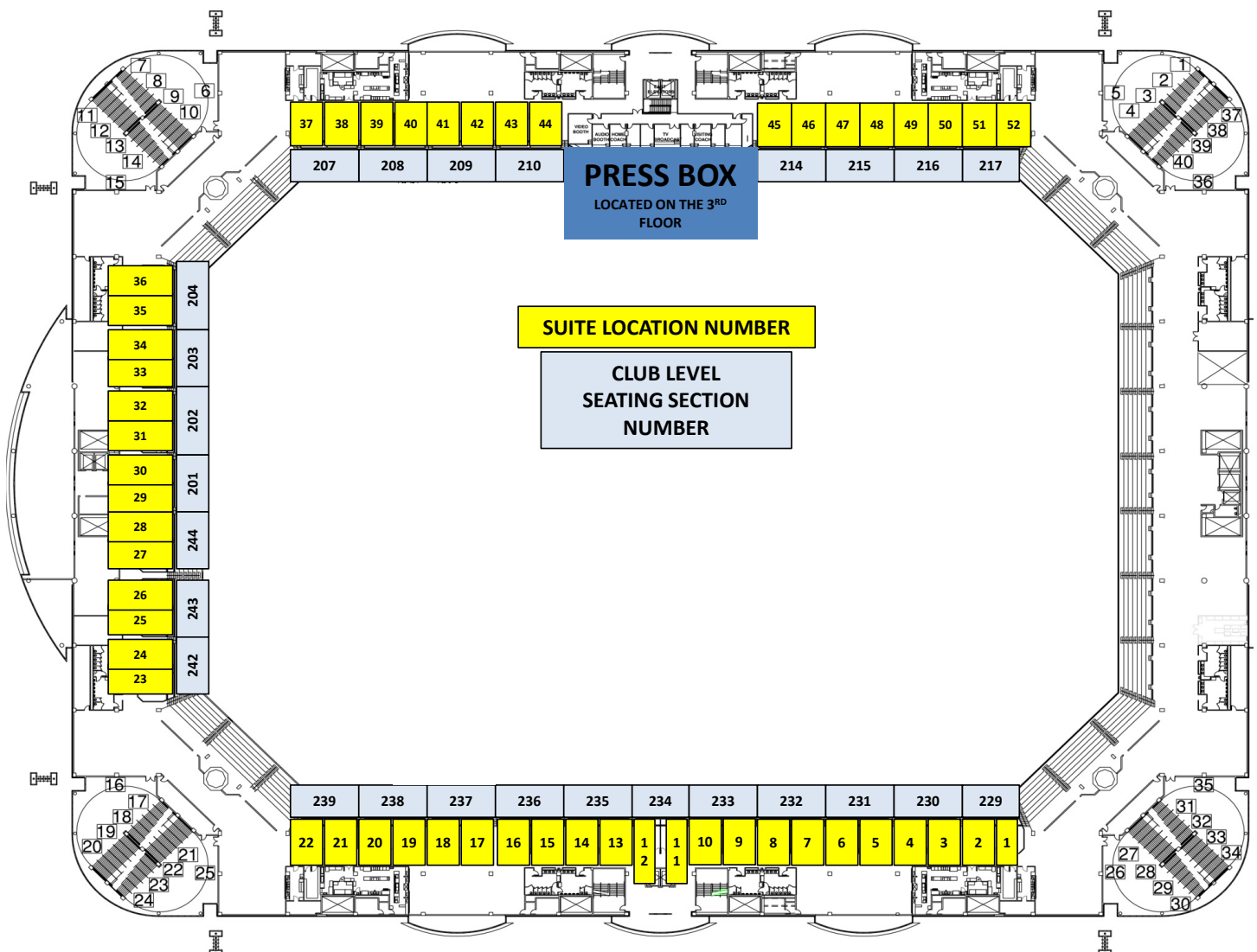

# Hospitality Spaces

## Hall of Fame Club

Located on the North end of the Club Level, the Hall of Fame Club offers over 4,000 square feet with spectacular views of the HEB Plaza and downtown San Antonio, two built in bars, and large flat screen TV's to enjoy the event from a private location.

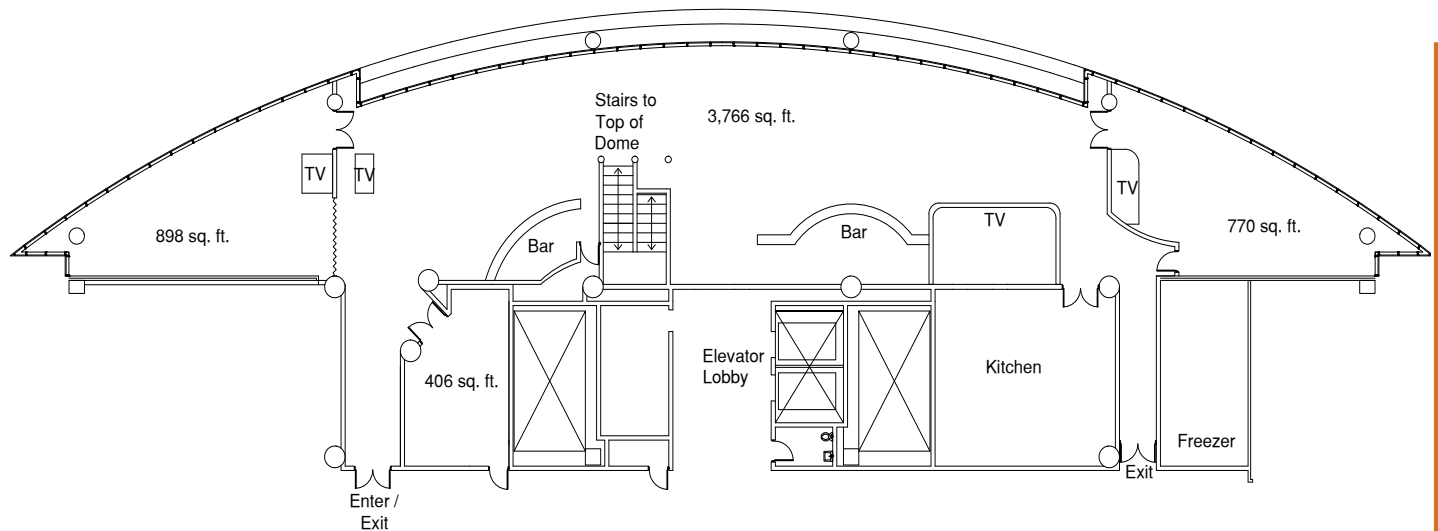

**BUILDING**

## South Club Eyebrow

Located on the South end of the Club Level, over 6,000 square feet of flexible and completely customizable space without any built in fixtures is the perfect place to make the Alamodome your own.

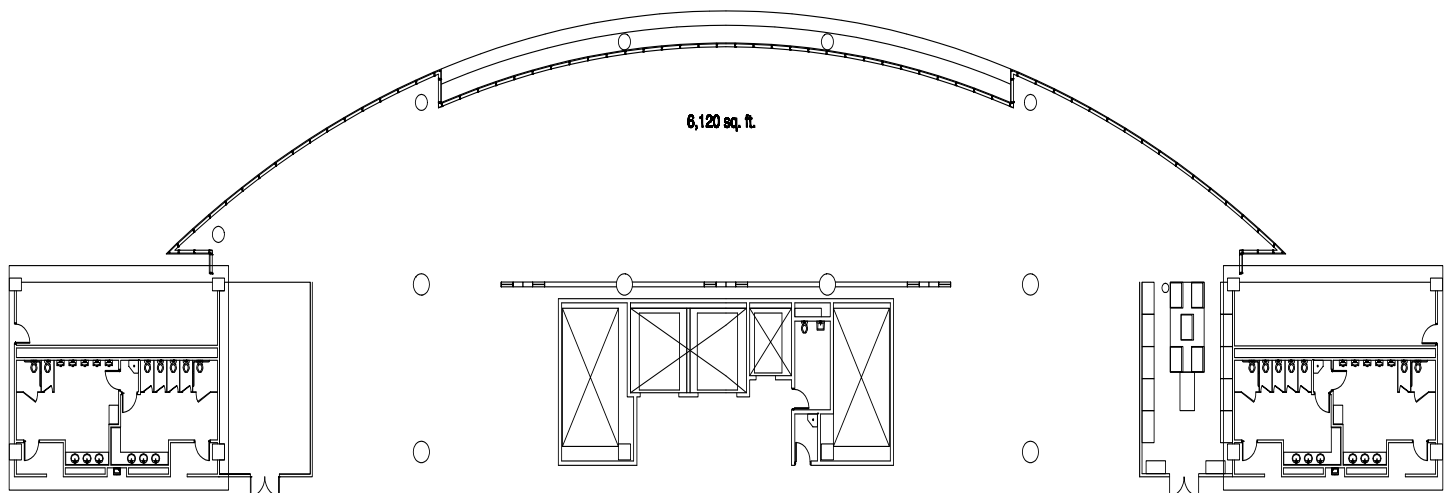

## Top of the Dome Club

Located on the North end of the Upper Level, the Top of the Dome Club can function as its own private 3,500+ square foot space, or use the connecting staircase to the Hall of Fame Club to double the size of your party.

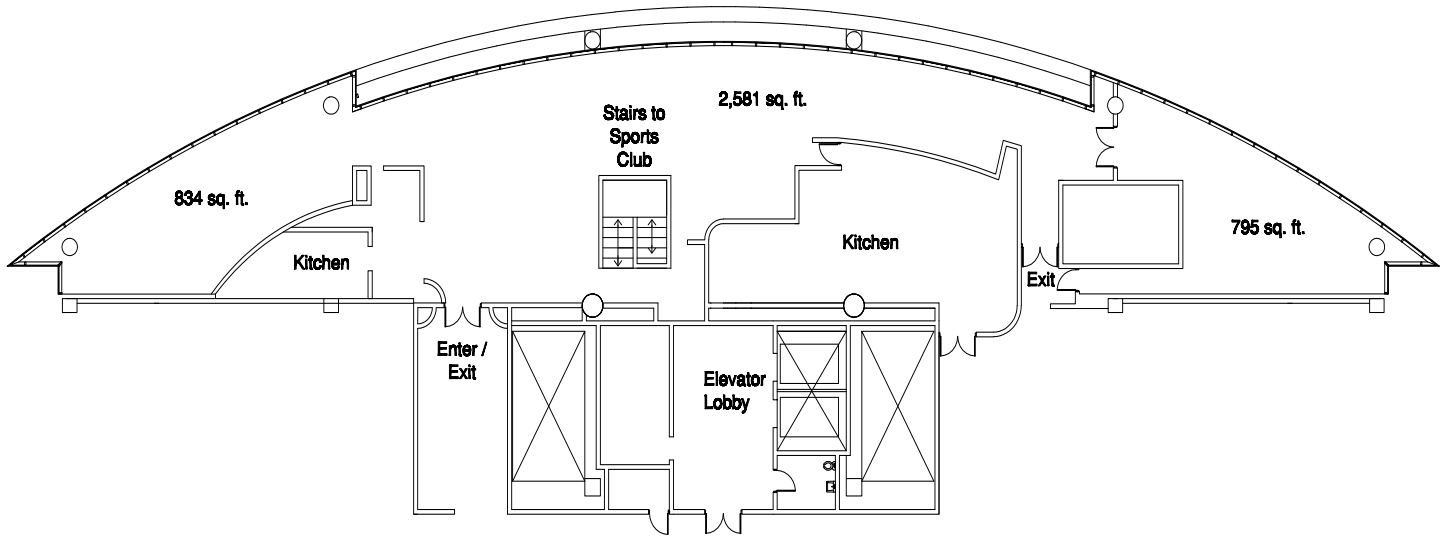

## Multi-purpose Room

This 23,000 square foot multi-purpose space is located on the North end of the field level. This brand new area features a separate loading dock, offering convenient access to Montana St.

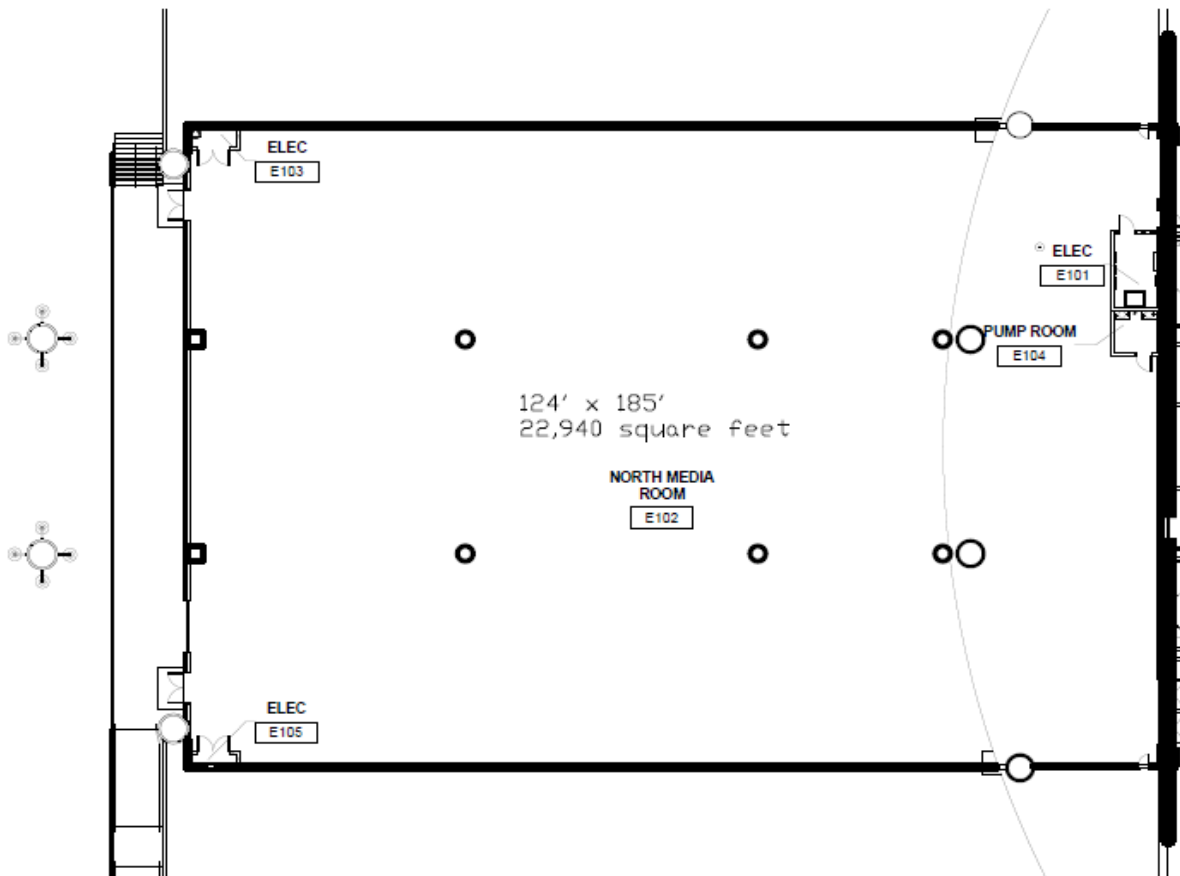

# Parking

At the Alamodome we understand that parking is an important concern for our event organizers and attendees, especially in a downtown setting. Our dedicated parking team has developed guidelines and procedures and will work with your Event Coordinator to plan and meet your transportation needs.

Lot*	Total Spaces	Lot Size	ADA	Bus	Location	Relation to Building
<b>A</b>	733	334,683sq. ft	114	0	Corner of East Cesar E. Chavez Blvd. and I-37 (U.S. Hwy 281) Frontage Road	South
<b>VIA</b>	136	Included in Lot A	0	0	Corner of East Cesar E. Chavez Blvd. and I-37 (U.S. Hwy 281) Frontage Road	South
<b>B</b>	968	343,976 sq. ft.	0	12	South Cherry Street	East
<b>C</b>	1,143	360,552 sq. ft.	0	0	South Cherry Street	East
<b>TOTAL</b>	<b>2,980</b>		<b>14</b>	<b>12</b>		

## Patron Drop-Off/Pick-Up Area

The designated Patron Drop-Off/Pick-Up Area is at the north end of Lot B. This lot is accessible from S. Cherry St.

## Taxis & Ride Shares

The designated taxi and ride share pick-up and drop-off location is the Convention Center Lot on the West side of I-37/281. The Alamodome is easily accessible via the pedestrian bridge connecting the parking lot to the HEB North Plaza.

## Bus Parking

Bus parking is available in the North section of Lot B. Busses enter and exit through the far North area of the parking lot. This exit remains blocked until the busses are ready to exit Lot B.

## Overnight Parking

Overnight parking is not permitted in any of the Alamodome parking lots. Production trucks/trailers are authorized to park overnight (dependant upon the individual event), but the tractors are not permitted to park overnight.

## Police

The San Antonio Police Department assists the Alamodome with traffic direction during many events. Because each event at the Alamodome varies in size, the amount of necessary man power also varies. The SAPD implements standard staffing for directing traffic during events. This

procedure is also dependant upon which parking lots and areas the Alamodome Parking Staff opens for the event.

## Load In/Load Out

### Loading Dock

- The loading dock is located at the south end of the Alamodome, in Parking Lot A, and is
- accessible via the Northbound I- 37/U.S. Route 281 Frontage Road. The loading dock features 4,200 square feet of space including eight truck bays with two direct access tunnels to the
- stadium. Loading Dock bays measure 17' 9" wide and 10' high. Bays are 82' deep.

### VIA Bollards & HEB Plaza Vehicle Access

- Vehicle access to the HEB Plaza on the North side of the Alamodome can be obtained with prior approval from your Event Coordinator. Access to the HEB Plaza will be limited to vehicles being used in the setup, display, or break down of events taking place on the Plaza. All vehicles entering the North or South Plazas must maintain a maximum weight of 250 lbs. per sq. ft. or less.
- Access to the HEB Plaza via Sunset Station is blocked by VIA Transportation owned bollards. If you must enter through Sunset Station, please provide your Event Coordinator with a schedule of the times you will require the bollards to be down at least a week in advance of your event. Any vehicle with a gross weight of 40k lbs. must obtain approval from VIA to enter through Sunset Station.

### Event Ingress/Egress Days

- Persons requesting Loading Dock access to load and/or drop off small items, such as documents or easily manageable single packages, (excluding commercial carriers such as UPS, FedEx and tractor-trailers) will be directed to park in Lot A. Such persons will be allowed access via the pedestrian walkway to the Southwest Tunnel entrance.
- Persons requesting Loading Dock access to load and/or drop off large or numerous items, (excluding commercial shippers such as UPS, FedEx and tractor-trailers) will be permitted to park in the designated 15-Minute Loading Zone parking spaces, if available. If the 15-Minute
- Loading Zone parking spaces are full, persons qualifying for Loading Zone parking will need to wait until a space becomes available. Such persons will be allowed access to the building through the Southeast Tunnel entrance.
- Alamodome tenants may park in the 15-Minute Loading Zone parking spaces for loading and unloading purposes at any time, provided space is available.

- Commercial carriers will be granted access to the appropriate loading dock bay as designated by the Security Officer staffing the Loading Dock gate.
- Additionally, two (2) Loading Dock Parking Passes will be issued for each event. Persons displaying these passes will be permitted to park in the designated parking area. Additional passes may be issued by Alamodome Administration, with notification to the Security Department.

## Event Days

- Loading Dock access on event days is restricted. Only commercial carriers staged at a Loading Dock bay and those persons possessing a Loading Dock Parking Pass may be granted access into the Loading Dock area. Parking for such vehicles will be as designated by the Security Officer staffing the Loading Dock gate.
- Licensee staff needing to load and/or unload in the Loading Dock area before the event is permitted to do so up to 2 hours prior to the start of the event. Licensee staff needing to load and/or unload after the end of the event may begin to do so 1 hour after the end of the event. There is no parking permitted in the loading dock area for these vehicles.

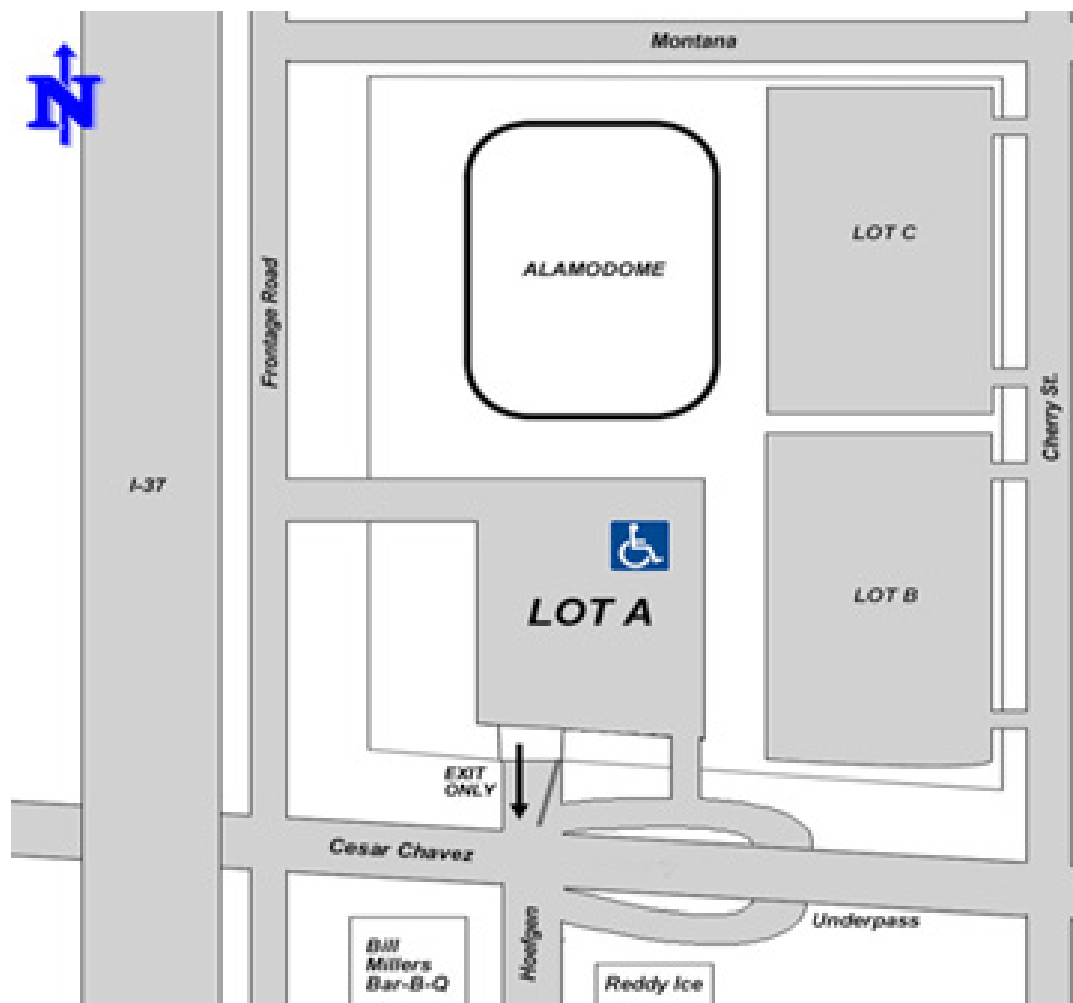







# PLANNING & SERVICES

## Booking Services Division

### Event Booking

Questions regarding the availability of dates and booking procedures should be directed to the Booking Coordinator.

### Follow-Up Evaluation

Following your event, the Booking Services division will forward an evaluation of our facility and our staff. Your success and satisfaction is our top priority, and we welcome the opportunity to meet and exceed your expectations.

## Event Services Division

### Event Coordination

Upon the completion of a signed contract, the Alamodome will assign an Event Coordinator to your account. This individual will become your primary contact throughout the event planning and execution process. The Event Coordinator is responsible for the coordination of the event requirements with the departments, technicians, and contractors of the Alamodome. The Event Coordinator is also your day-of event contact, and will oversee all facility operations under the supervision of upper management.

### Other functions of the Event Services Division

- Staffing and cost estimates
- Floor plan and coordination and approval with the San Antonio Fire Department
- Shipping and receiving assistance
- Production and technical specifications
- Preliminary invoice

### Production Meetings

The Event Coordinator will conduct a production meeting prior to your load-in and arrival to review any specifications and arrangements regarding the event. All facility divisions and contractors will participate to ensure all aspects of the event have been thoroughly reviewed. Prior to the start of the event, a pre-event briefing will be held with all department supervisors. Your participation in both of these sessions is encouraged.

## Box Office & Ticketing

### Ticketmaster

The Alamodome is a Ticketmaster exclusive facility. The selling of tickets through any other ticket agency, or by any other means outside of Ticketmaster is prohibited. Additionally, tickets may not be sold on a consignment basis without the approval of the Box Office Manager.

You should contact the Box Office Manager to discuss ticket sales on Ticketmaster. Please note that typically, once all information is received to build an event on Ticketmaster, the creation process will take up to four (4) business days to complete. Please keep this in mind when planning for your event on sale.

Once an event is on sale, any changes made to the event such as added discounts, pricing changes, artist changes, ticket header changes, etc., will be approximately three (3) business days to complete. Again, please keep this in mind when planning your event

### Box Office Hours

The Southwest Box office is open Monday thru Friday from 10am - 5pm and as necessary for events. On event days, the box office typically opens at least two hours before the event. Hours may vary based on projected ticket sales and/or promoter requests.

### Box Office Staffing

The Alamodome will provide staffing during your event. The number of sellers will be determined by the Box Office Manager and is based on the size of the event, historical data, and the public interest in the event during the days leading up to the event itself.

### Settlement

Event settlement is conducted by the City of San Antonio Fiscal division. Please contact your Event Coordinator to determine the timing of your event settlement.

### Group Sales

The Alamodome does not offer group sale tickets. Coordinating group sales is a responsibility of the promoter. Group Sales for the Alamodome are typically outsourced. For more information or to learn about our preferred group sales vendor, please contact your Event Coordinator.

## Building Policies

### Camera/Recording Policy

Video and audio recorders are not permitted inside the Alamodome unless approved in advance by show or building management.

### Children's Entry policy

All guests ages 2 and over are required to have a ticket for admission, unless otherwise specified.

### Re-Entry Policy

The Alamodome has a no re-entry policy. Re-entry on the same ticket is prohibited.

### Prohibited Items

For safety reasons, prohibited items include but are not limited to:

- Alcohol, drugs, illegal substances, or any paraphernalia associated with drug use
- Audio/Visual recorders and professional cameras, tripods, or selfie sticks
- Cans, bottles, coolers or other similar containers
- Fireworks
- Flags/signs with poles
- Drones
- Laser pens/pointers of any type
- noisemakers such as air horns and whistles
- Outside food or drinks
- Oversized bags, backpacks, duffel bags, or diaper bags
- Pepper spray/mace
- Weapons of any type, including chains, knives, firearms and spiked jewelry
- Any other items deemed unacceptable by event/building management

### Public Policies

- No soliciting
- Tobacco & smoke free environment. Smoking locations are on the East and West 50 doors on the Plaza Level.
- Re-entry is not allowed

- There is always the possibility of the use of pyro, strobes, lasers, and confetti during an event
- The Alamodome prohibits scalping and the resale of tickets on property
- If an item is revealed during a search, patrons may dispose of the item or they may return the item to their vehicle. The Alamodome does not safeguard any personal belongings or other items.

## Animals

Animals are not permitted in the Alamodome with the exception of service animals.

All events displaying live animals must notify the Alamodome in writing prior to the event date. All animals must have health documents as required by federal, state and municipality statuses.

## Balloons

Helium balloons are not allowed in any part of the facility, either for display, for sale, or as gifts. For decoration purposes, air-filled balloons may be used. The Licensee is responsible for informing exhibitors of this policy. The facilities reserve the right to remove any helium-filled balloons at Licensee's expense.

## Deliveries

Event deliveries may be made to the Alamodome a maximum of three days in advance of and during an event. Please address all deliveries to your Event Coordinator and include the name of the Event. All deliveries are to be shipped to 100 Montana Street, San Antonio, TX 78203. Once received, deliveries will be stored in the Alamodome's Inventory Center. Contact your Event Coordinator with a list of known deliveries prior to their arrival. The Alamodome is not responsible for items that may be lost or damaged during shipment.

## Recycling

The Alamodome pursues conservation policies in regards to energy, water and recycling whenever possible. Since 2006, the Alamodome has created several "green" initiatives to reduce the number of chemicals used and to conserve water and energy. The facility recycles various items and materials including glass, plastic, aluminum.

## Service Contractors

Certain services provided within the facility are on an exclusive or preferred (non-exclusive) basis. Please contact your Event Coordinator for more information.

## Building Policies Continued...

### Posters & Signage

With prior approval by the Event Coordinator, event- related and professionally printed banners, posters, and signs may be displayed in various locations inside and outside of the facility. Licensee is responsible for acquiring the measurements needed for signage. Under no circumstances should any posters, signs, etc. be attached to walls, doors, or windows. Licensee is responsible for the removal of all such posters, signs, etc., and any cleaning of residue left by item, at the conclusion of their event. No decorative or structural items may be attached to or hung from any overhead beam, column, handrail, utility pipe, exterior wall, or fence without prior written approval. The Licensee will be charged for the labor and materials required for removal resulting from violation of this policy.

### Stickers, Decals, & Adhesives

The use of any type of adhesives on any facility owned surface is strictly prohibited. Licensee is responsible for the labor and materials required for cleanup and repair resulting from violation of this policy.

### Tape

The use of double-sided tape on any facility surface is strictly prohibited. Painters or decorators tape is permitted on surfaces with the exception of stained concrete. Licensee is responsible for ensuring all tape is removed at the conclusion of the event. Licensee is responsible for the labor and materials required for cleanup and repair resulting from violations of this policy.

### Clear Bag Policy

For the safety of your staff and guests, the Alamodome will enforce the clear bag policy explained on the following page.

# ALAMODOME CLEAR BAG POLICY

To provide a safer environment for the public and in order to expedite fan entry into the Alamodome, we have implemented a Clear Bag Policy (very similar to the NFL Clear Bag policy) that limits the size and type of bags that may be brought into the Alamodome.

## Approved Bags



Bags smaller than  
5.5"x 8.5"

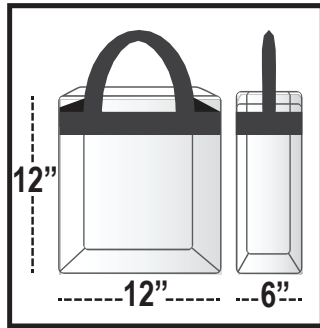

Clear Bag smaller than  
12" x 6" x 12"



1-Gallon Plastic  
Freezer Bag



Medically Necessary  
and Diaper Bags\*

## Bags not allowed into Alamodome



Backpack



Camera Case



Mesh Bag



Purse



Seat Cushion



Clear Backpack



Tinted Plastic Bag



Over-sized Tote Bag



Binoculars Case



Printed Pattern  
Plastic Bag



Folding Chair Bag  
(Folding Chair not allowed)

## Open & Concealed Carry Policy

The Alamodome complies with federal and state laws and city ordinances regarding the lawful carrying and possessing of weapons within Department facilities. ("LTC" – License to Carry)

Illegal weapons are prohibited at all times. Lawfully carried weapons (concealed or openly carried) are permitted under most circumstances in areas accessible to the public.

As a contracting client paying for the private use of facility and event related space, you may request your event be considered "all Weapons-Free" (banning all weapons) or allow licensed handgun permit holders to enter your event.

If requesting an "All Weapons-Free" event, The Alamodome will provide the necessary signage (Texas Penal Code Section 30.06 [c][3][A] and 30.07 [c][3][A]). Placement of such signage will be posted during the period of the event by a contracted 3rd Party and remain in place until the end of the fully executed term shown in this License Agreement unless specifically requested to be removed.

AS A GOVERNMENT OWNED BUILDING, ALAMODOME STAFF IS NOT AUTHORIZED TO MAKE ANY DECISIONS ON WHETHER TO POST THE APPLICABLE SIGNAGE FOR ANY EVENT

## Security & Safety

The Alamodome is committed to providing a safe and secure environment for employees, performers, promoters and guests. The Alamodome offers the following security and safety services.

- Security Control room staffed 24 hours a day
- Roving security officers inside and outside the facility
- Medical personnel on standby
- First aid facilities throughout

## Event Command Center

The Alamodome will have an Event Command Center in operation during your event. This command center serves as the central operational headquarters for all events. Representatives from Alamodome divisions as well as police and fire will be monitoring all activities and communications during the event.



## Police Officers

Licensee is responsible for security in the form of Off- Duty San Antonio Police Department (SAPD) officers for all events including public events and events in which alcohol is served. The final number of officers is determined solely by the SAPD Off-Duty Employment Unit (ODEU) based on event requirements. No event staff, other than SAPD ODEU security, are allowed to physically intervene with anyone within the facilities. SAPD is the exclusive provider for security, including overnight security.

## Peer Security

Supplemental security staff may only be obtained from the Alamodome's contracted event provider. Please contact your Event Coordinator for more information.

## Event Screenings

Walk-through metal detectors and/or hand wands are used for the safety of all staff, guests, and performers for all events. In addition, bags will be searched prior to entering the facility.

## Bomb Sweeps

Bombs sweeps may be arranged at the request of the promoter. Please contact your Event Coordinator for more details.

## Guest Services

### Entrances

The Alamodome has (8) possible sets of entrance doors and (174) individual doors for event use:

- (27) North Glass Doors & (27) South Glass Doors
- (8) East Glass Doors & (8) West Glass Doors
- (14) Southeast Metal Doors & (14) Southwest Metal Doors
- (18) Northeast Metal Doors & (18) Northwest Metal Doors
- (10) East- Southeast Metal Doors & (10) West- Southwest Metal Doors
- (10) East- Northeast Metal Doors & (10) West- Northwest Metal Doors

### Passenger Elevators

- (2) on the North, (2) on the East, (2) on the West, (1) on the South.
- Ten persons and or 4,500 lb. weight limit.

## Escalators

- (2) from North Plaza Level to Field Level.

## Restrooms

Restrooms are located on all levels and are equipped to meet the needs of all guests, including those with disabilities. Family restrooms are available on all general public access levels near the North and South elevators.

## Automatic Teller Machines (ATMs)

ATM Machines are located on all general public access levels.

## Guest Relations Centers

The Alamodome offers two Guest Relations Centers, one on the North Plaza and one on the South Plaza Level. These centers will assist guests with facility and event questions and general assistance.

## Lost & Found

During the event, lost items can be brought to the Guest Relations Centers to be claimed. At the close of the event, any items as well as the lost items log will be stored in Security Control.

## ADA Services

The Alamodome strives to provide an unequalled experience for all patrons and is fully ADA compliant. Assisted Listening Devices are available at the North and South Information Booths.

Designated accessibility seats are located on the Plaza, Mezzanine, Club, and Upper Levels. There are 272 specially designated accessibility seats plus 312 attendant seats (584 seats) available. Wheelchairs are available to assist patrons to their seat once they have entered the Alamodome, but may not be brought outside the building for patrons use. If you are expecting attendees with special needs, please speak with your Event Coordinator so that all necessary accommodations may be made in advance.

# Advertising & Promotion

## Outdoor Marquee

The Alamodome's Marquee is located in Parking Lot A and is visible from Interstate 37 and the surrounding area. The Alamodome will run between one and three graphics in a sequence, similar to a slideshow, per event. Graphics may be run up to 45 days prior to an event. Graphics must be full color, 400 x 144 pixels, and are best if "saved for web" JPEGs at 100% size in RGB color mode.

Resolution is 72dpi. All graphics must be sent in the correct size formatting.

No sponsorship logos can be used unless part of the event's name. The following is an example:

- YES: Valero Alamo Bowl
- NO: Alamo Bowl Presented by Valero

## Social Media

The Alamodome promotes events taking place via social media on Facebook, Twitter, and Instagram. Specific promoter request for advertising will be handled on a case-by-case basis. Ticket promotions, giveaways, and other fan interaction promotions are welcome and encouraged.

Follow the Alamodome:

- Facebook: [facebook.com/Alamodome](https://facebook.com/Alamodome)
- Twitter: @Alamodome
- Instagram: AlamodomeSA

## Outdoor Marquee

The Alamodome's Marquee is located in Parking Lot A and is visible from Interstate 37 and the surrounding area.

- The Alamodome will run between one and three graphics in a sequence, similar to a slideshow, per event. Graphics may be run up to 45 days prior to an event.
- Graphics must be full color, 400 x 144 pixels, and are best if "saved for web" JPEGs at 100% size in RGB color mode. Resolution is 72dpi.

## Press Release

Please include a press release along with your graphics consisting of artist, ticket and event information and a description of the event for the information page.

## E-Blasts & Promotional Announcements

Marketing questions concerning E-Blasts and Promotional Announcements should be directed to our Marketing Manager.

## Website

We will promote your event via [www.alamodome.com](http://www.alamodome.com). The website requires 2 graphics:

- A photo or logo 560x350 pixels horizontal
- An event logo 160x100 pixels horizontal.

## Alamodome Logo

Licensee or exhibitors may not use Alamodome logos for any purpose without the prior approval.

The use of Alamodome logos in any brochures, advertisements, or other publicity must be approved in advance. For questions or concerns regarding please contact our Marketing Manager.

## Star Partner Promotions

The Alamodome has a number of Star Partners that are entitled to the following during all events:

- H-E-B, Pepsi, and University Health systems will each will receive a minimum of two minutes and thirty seconds of features on the digital ribbon boards during the event. They will also receive a minimum of four (4) feature executions on the LED video scoreboards pre, during event.
- Alamo Candy will receive a total of 30 seconds of features on the digital ribbon boards pre and during event.

## Food & Beverage

Savor is the exclusive Food and Beverage provider at the Alamodome. A leader in delivering high quality food & beverage options, the Savor team will work with you create and customize an all-star menu for you and your guests.

## Concessions

The Alamodome features a wide range of concessions that make dining at the Alamodome a treat.

Concessions feature flavors and brands such as Anne's Old Fashioned Ice Cream Bars, D&D Kettle Corn, Igloo Frozen Drinks, Flamingo Rey's Island Shaved Ice, Maui Wowi Hawaiian Smoothies & Frozen Cocktails, Big Bib Barbecue, the Green Fork, and Los Barrios.

## Catering/Premium Services

Whether personal or corporate, large or small, from field level, suite level or on the upper deck, Savor Black Tie is your in-house caterer at the Alamo dome. At Savor Black Tie we take pride in the work we do and the service we provide. Our years of experience, qualified staff, excellent services coordination and planning skills, can guarantee your full satisfaction. You can count on our Premium Service Department to deliver impeccable food services; our experts in the culinary field can accommodate all your menu options. We are confident we can deliver the highest quality of service possible and hope for the opportunity to serve you. If you're planning a corporate event, convention, fundraiser, organizational or personal event, count on us to ensure that your special day is also a memorable one that you and your guests will enjoy.

## Food & Beverage Policies

- Unless contractually agreed upon, all backstage and special event food and beverage will be arranged and provided by our exclusive food and beverage partner. Those wishing to use another provider must agree to and abide by the catering buy-out terms and conditions.
- Approved vendors may offer sampling of products during the event. Samples may be no larger than 1 ounce and each vendor must obtain a permit. Vendors can contact the SAFD by phone (210) 207-0013 to inquire about the permit requirements.
- Unless notified otherwise, food and beverages brought onto the parking lot areas is permissible. Food and beverages from outside sources cannot be brought into the Alamodome building itself.
- Alcoholic beverages may be served within the facilities during certain events. Licensee is responsible for obtaining off-duty San Antonio Police Department (SAPD) officers at any event in which alcohol is being served or sold. The final number of officers is determined solely by the SAPD Off-Duty Employment Unit (ODEU) based on event requirements.
- The service or sale of alcohol to minors is prohibited by law. We ID every time. Any concerns regarding alcohol outside of these parameters need to be addressed directly with your alcohol provider.





# PRODUCTION

# A/V Specs for Video Walls and Ribbons

\*All graphics and videos must be submitted one week prior to event

## Corner Video Walls

HD Video Commercials & Moving Graphics:

- 1080i or 1080p / 29.97fps
- .mov or mpg4
- NO 24 FPS COMMERCIALS
- NO FLASH FILES/ FLASH ANIMATION

Stills:

- .png (if alpha needed) / .jpeg (If alpha not needed)
- Width: 1920 / Height: 1080
- Resolution: 72 Pixels/Inch
- Color Mode: RGB Color / 8 bit
- Color Profile: Don't Color Manage
- Pixel Aspect Ratio: Square Pixels
- Use these settings in Photoshop

## 360 Ribbons

Moving Graphics:

\*The ribbon boards are divided into 8 separate sections. Please keep this in mind when creating a continuous 360 ring.

- Width: 4544px / Height: 64px
- Pixel aspect ratio: Square Pixels
- Frame Rate: 29.97 fps
- .mov or mpg4
- NO FLASH FILES/ FLASH ANIMATION

Stills:

\*The ribbon boards are divided into 8 separate sections. Please keep this in mind when creating a continuous 360 ring.

- .jpeg / .targa / .png



- Width: 4544px / Height: 64px
- Resolution: 72 Pixels/Inch
- Color Mode: RGB Color / 8 bit
- Color Profile: Don't Color Manage
- Use these settings in Photoshop

## North Center Hung Video Boards

### HD Video Commercials & Moving Graphics:

- 1080i / 29.97fps
- .mov or mpg4
- NO 24 FPS COMMERCIALS
- NO FLASH FILES/ FLASH ANAMATION

### Stills:

- Width: 1920 / Height: 1080
- .png (if alpha needed) / .jpeg (If alpha not needed)
- Resolution: 72 Pixels/Inch
- Color Mode: RGB Color / 8 bit
- Color Profile: Don't Color Manage
- Pixel Aspect Ratio: Square Pixels
- Use these settings in Photoshop

## Matrix Boards

### Moving Graphics:

- Width: 128px / Height: 160px
- Pixel aspect ratio: Square Pixels
- Frame Rate: 29.97 fps
- Drop Frame
- Resolution: Full
- .mov ONLY
- NO FLASH FILES/ FLASH ANAMATION

#### Stills:

- jpeg ONLY
- Width: 128px / Height: 160px
- Resolution: 72 Pixels/Inch
- Color Mode: RGB Color / 8 bit
- Color Profile: Don't Color Manage
- Pixel Aspect Ratio: Square Pixels

## Equipment & Personnel

The Alamodome has Video Production Equipment and Personnel that can be provided at an additional cost per event. All Equipment and Personnel must be requested at least two weeks prior to the scheduled event.

#### Cameras:

- 3 -- Ikegami HDK-65C/BDT Cameras with XJ80X8.8B/P01-DSS with full camera support and CCU's 1080i
- 3 -- Ikegami HDK-65C/BDT Cameras with HJ24EX7.5B with full camera support and CCU's 1080i
- 1 -- Ikegami HDK-65C/BDT wireless Camera with HJ14eX4.3B with full camera support and CCU's 1080i

#### Instant Replay:

- 1 -- Evertz DreamCatcher Replay System 8 channels, pan and zoom, High frame rate camera support

#### Ribbons & Graphics:

- 2 -- Ross Dual Channel Xpression Studio CG

#### Switcher

- 1 -- Ross Acuity 4ME, 32 input switcher

#### Digital Recorder:

- 4 -- AJA 4K/Ultra HD and 2K/HD Recorder/Player

## Show Power Availability

### East Loading Dock:

- (3) 200amp 3phase/208v
- (2) 200A (1) 150A
- (1) 30A 3Phase 208V

### West Loading Dock:

- (3) 200amp 3phase/208v
- (3) 30A 3Phase 208V &
- (3) 50A 3Phase 208V

### South East Tunnel:

- (2) 600amp 3phase/208v
- (1) 400 amp 3phase/208v
- (1) 100 amp 3phase/208v

### East 50-Yard Line

- (1) 600 amp 3phase/208v
- (1) 400 amp 3phase/208v

### West 50-Yard Line:

- (1) 600 amp 3phase/208v
- (1) 400 amp 3phase/208v

### Catwalk Disconnect – Center Stadium:

- (1) 800 amp 3phase/208v

### Quad C Electrical Room

- (1) 600A 3Phase 208V (NO CAMS; Distribution Panel w/ Circuit Breaker)
- (1) 400A 3Phase 208V (NO CAMS; Distribution Panel w/ Circuit Breaker)

### Greisonbach House (Lot A):

- (3) 200amp 3phase/240v



## Rigging

The rigging of items weighing less than 250 lbs. can be performed by your general services contractor (decorator), or another qualified provider. The rigging of items that weigh over 250 lbs. must be reviewed and approved by a representative of the Alamodome's exclusive rigging company. A certified rigger must hang everything from the chain hoist/motor up to the ceiling.

## Roof, Sound, & Lighting Grid Measurements

- Beams: 10'-6" wide center to center
- Catwalk: 160' from floor
- Bowed Truss Steel (Bottom): 120' from floor
- Bottom of Steel: 164-4" from floor
- Top of Steel: 171' from floor
- Arena North Concert Grid: 60' x 80' 30pt. grid that supports 162k max weight
- Center Floor Concert Grid: 60' x 80' 30pt. grid that supports 162k max weight
- Center Floor Scoreboard Grid: 38' x 57' 18pt. grid that supports 90k max weight
- South Floor Concert Grid: 60' x 80' 35pt. grid that supports 162k max weight

## Roof, Sound, & Lighting Grid Weight Capacities

- General: 4,000 lbs. per truss; 5 pts. per hour due to size and height

## Seating Unit

Interval Unit Weight:

- 42' unit weighs 26,250 lbs. plus 13,440 lbs. of seating = 39,690 lbs.
- 36' unit weighs 22,500 lbs. plus 10,080 lbs. of seating = 32,580 lbs.

## Stagehands

Licensee is responsible for utilizing a certified stagehand for requirements including rigging, lighting, sound, etc. Stagehand requirements can be coordinated through Upstage Center Inc, the preferred provider of rigging service.

## Floor Weight Capacities

Stadium floor concrete : 3500PSI and 6000PSI concrete.

ice sheets: 1100 PSF.

The inside loading dock:1100 PSF

South plaza over the loading dock: 1100 PSF



# Fire Safety Requirements

## Pyrotechnics

Licensee and all contractors must comply with the San Antonio Fire Department's Fire Regulations for Public Assembly Occupancies. A permit is required for the use of pyrotechnics during events.

Please contact Shirley Guzman with SAFD by phone, (210) 207-0013, or by email at shirley.guzman@sanantonio.gov for permitting inquiries.

## Automobiles

Personally-Owned Vehicles (POV's) may not be driven into the facility without permission from your Event Coordinator and may only be operated inside the building for loading and unloading of large equipment. Vehicles may be displayed with prior approval from the City of San Antonio Fire Marshal. It is the responsibility of the Licensee to ensure that exhibitors are aware of these guidelines.

## Floor Plans

The Alamodome and San Antonio Fire Marshals must approve all seating prior to onsale. The blocking of aisles, exits or corridors of any type is prohibited.

## Electrical Wiring

Electrical cords will be grounded and UL listed. Extension cords may be used provided they are plugged directly into an outlet or an approved power strip and are rated for the intended power use.

## Standby Inspector

If determined necessary by the San Antonio Fire Department, a standby fire marshal will be present during the event. Any costs for this additional requirement will be the responsibility of the promoter.

## Indoor Structures and Enclosed Tenting

All Indoor enclosed structures are required to have operational smoke detectors and fire extinguishers. All structures are subject to approval by the fire marshal.

## Permitting

The Development Services Department for the City of San Antonio has outlined the following process for permitting. Items possibly needing permitting include but are not limited to generators, tents and stages. Please contact the Development Services Department to ensure you complete proper permitting.

Andrew Espinoza  
Development Services Manager  
(210) 207-0152  
aespinoza@sanantonio.gov

The following items should be submitted to the above contact:

1. Temporary Use Application:

a. <https://docsonline.sanantonio.gov/FileUploads/DSD/TemporaryUsesApplication.pdf>

2. Please provide two hard copies of the site plan of the event

- a. Identify all tents
- b. Identify all stages/temporary event structures
- c. Identify location of generators

3. A city registered Texas Master Electrician will need to secure an electrical permit for the generators

a. [https://docsonline.sanantonio.gov/FileUploads/DSD/DSD\\_Electrical\\_Application.pdf](https://docsonline.sanantonio.gov/FileUploads/DSD/DSD_Electrical_Application.pdf)

4. Please provide total square footage, number of stories, occupant load, floor plan for

- a. All tents
- b. All stages/temporary event structures

5. Please confirm that a safety and traffic plan have been put into place

6. Please provide two hard copies of the Texas engineered drawings, specs, fire rating fabric certificate, and anchoring details for tents over 5,000 sq. ft. (two hard copies)

7. Please provide two hard copies of the Texas engineered drawings, specs, and bracing details for temporary event structures (Stages, scaffolding, rigging, platforms, and visual effect structures over 400 sq. ft.)

8. Inspections will include Building, Fire, and Electrical

- a. Building will require a third party inspection report in addition to CoSA building inspection for any items outlined in bullet points 5 & 6





# EQUIPMENT & LABOR RATE CARD

## Public Safety (per hour)

Public Safety Manager	\$34.50	SAPD Supervisor (3 Hour Min.)*	\$55.00/\$48.00
Public Safety Supervisor	\$25.25	SAPD Officer (3 Hour Min.)*	\$46.04/\$39.04
Public Safety Officer	\$21.65	SAFD	\$82.40
In-House Security Officer	\$16.50	Medical Services ALS/BLS	\$55.00/\$48.00
		Ambulance	Quotes Available

\* Higher rate applies to first hour of service with lower rate being applied to all hours thereafter.

## Event Services (per hour)

Event Coordinator	\$20.00	Usher Supervisor	\$19.50
PBX Operator	\$17.50	Floor Supervisor	\$19.50
Uniform Attendant	\$17.00	Usher	\$17.00
Gate Captain	\$19.50	Elevator Operator	\$17.00
Ticket Taker	\$17.00		

## Box Office (per hour)

Rental Fee	\$500.00/day	Box Office Manager	\$36.50
Security Deposit	\$500.00/use	Box Office Supervisor	\$26.00
Box Office Manager (Off-site)	\$40.00	Ticket Seller	\$16.50
Ticket Seller (Off-site)	\$35.00		

## Operations and Maintenance (per hour)

Operations Supervisor	\$25.00	Head Turf Manager	\$45.00
Operations Staff	\$22.50	Equipment Operator	\$25.00
HVAC System Operator	\$55.00	Electrician	\$45.00
Plumber	\$45.00		

## Other (per hour)

Parking Supervisor	\$27.00	Cleaning Supervisor	\$20.50
Parking Attendant	\$16.50	Cleaning Attendant	\$19.00

## A/V and Telecommunications Equipment & Services (per unit/per event) (AR –Advance Rate; SR - Show Rate)

A/V			
In-House Closed Circuit Monitors	\$600.00	Additional Closed Circuit Channel	\$100.00
TV Cart	\$20.00 AR	TV Cart	\$25.00 SR
60" Zenith Color Television	\$350.00 AR	60" Zenith Color Television	\$400.00 SR
Beta Deck Rental	\$150.00/hour	Edit Suite Rental	\$150.00/hour
Broadcast Support			
Camera Hookup – Triax	\$195.00	Fiber Connectivity	\$370.00
ENG Hookup – 1 Video, 2 Audio	\$120.00	Fiber Connectivity to Transmission Carrier	\$75.00
Audio/Video Interconnectivity	\$185.00		
CATV/DMX Services			
Cable Television	\$150.00 AR	Cable Television	\$200.00 SR
Intercom			
Wired Intercom	\$30.00	Wireless Intercom	\$60.00



# EQUIPMENT & LABOR RATE CARD

Microphones & Direct Boxes			
Basic Mic. with Cable & Stand	\$25.00	Wireless Headset Mic (must include wireless system direct box)	\$25.00
Wireless Mic System	\$75.00	Compact Disc Player (Single Player)	\$50.00
Direct Box	\$20.00		
Miscellaneous			
Batteries	\$10.00	CD's and Cassettes	\$15.00
Park & Power	\$250/Truck		
P.A. Packages			
Small (8 channel power mixes, 2ea. speakers w/stands, 2ea. wired mics w/stands and all cables)	\$350.00	Medium (8 channel power mixes, 4ea. speakers w/stands, 4ea. wired mics w/stands and all cables)	\$500.00
Large (16 channel mixer, 2ea. Large speakers, 2ea. floor monitors, 1ea. stereo amplifier, 6ea. wired mics w/stands and all cables)	\$1,000.00	Active Press Box (16 channel (12M/4L)	\$60.00
Arena (3-way EV system hung around Jumbotron)	\$2,000.00	Stadium (16 EV Horns Center Hung)	\$2,000.00
Mini Snake Box and Fan-Out (50'-100' 6 or 12 channels)	\$20.00	Audio Snake Box and Fan-Out (100' - 24 channels)	\$50.00
Audio Patch Fee	\$30.00	Com Drop	\$20.00
Single Analog Line	\$250.00 AR	Single Analog Line	\$275.00 SR
Digital Multi-Service Line 2-Lines	\$270.00 AR	Digital Multi-Service Line 2-Lines	\$300.00 SR
Additional Lines on Multi Line Service	\$35.00 AR	Additional Lines on Multi Line Service	\$60.00 SR
Dry Pair Connection – SBC D-Marc	\$200.00	Dry Pair Connection – Internal	\$100.00
Voice Mail	\$15.00 AR	Voice Mail	\$20.00 SR
Long Distance Restriction per Line	\$5.00 AR	Long Distance Restriction per line	\$10.00 SR
Ringdown with Instruments	\$200.00	Telephone Technician Services	\$90.00/hour
Dedicated T1 Line	By Quote	Dedicated Internet Line	\$950.00
Video Pass Through*	\$2,500.00	Video Production	By Quote
Ikegami HDK-65C/BDT Cameras with XJ80X8.8B/P01-DSS with full camera support and CCU's 1080i or 720p	\$1,200 w/Camera Operator	Ikegami HDK-65C/BDT Cameras with HJ24EX7.5B IASE S with full camera support and CCU's 1080i or 720p	\$900 w/Camera Operator
Ikegami HDK-65C/BDT wireless Camera with HJ14eX4.3B IASE with full camera support and CCU's 1080i or 720p	\$1,000 w/Camera Operator	When using a camera during an event a EIC and/or a camera control operator must be present	\$600
Temp. Phone (De-) Activation	\$15.00	Domestic Long Distance per Minute	\$0.40



## EQUIPMENT & LABOR RATE CARD

When using a camera that is hand held and tethered with a cable such as triax, coax or fiber, one or more utilities must be present	\$250	Evertz DreamCatcher Replay System 8 channels, pan and zoom, High frame rate camera support	\$750 w/Replay Operator
Ross Dual Channel Xpression Studio CG	\$800 w/ Operator No Build Time	Ross Acuity 4ME, 32 input switcher	\$800 w/Technical Director
4 AJA 4K/Ultra HD and 2K/HD Recorder/Player	\$100	360 VIDEO RING	\$3,600
HD Video Walls (4)	\$1250 each	In Stadium Sound System	\$3,600
For large events an extra audio tech (A2) must be present	\$600 per Audio Tech		

### Equipment Rental (per unit/per event)

Basketball Floor	By Quote	Pallet Jack	\$50.00
8' Bike Rack	\$25.00	Pipe & Drape	\$2500
Camera Platform	\$400.00	Podium	\$35.00
Chairs	\$2.50	Projection Screen	\$35.00
Chalkboard	\$25.00	Riser	\$45.00
Chrome Stanchion	\$25.00	Scissor Lift	\$100.00
Dry Erase Board	\$25.00	Shore Power	\$200.00
Easel	\$25.00	Spotlight (Zenon Gladiator 3)	\$200.00
Extension Cord	\$25.00	Stage (60' x 40')	\$3,500.00
Sports Turf	By Quote	Table (8' x 30")	\$15.00
Forklift (6 Ton) and Driver	\$650.00	Table (8' x 18")	\$15.00
Forklift (3 Ton) and Driver	\$600.00	Table (60" Round)	\$15.00
Ice Floor	By Quote	Table Dolly	\$20.00
Inertia Barricade	\$2,000.00	Yellow Jacket Cable Ramp	\$25.00
Lost Room Key	\$100.00		

